



***SALICE***

*Glow Easy • Glow+*

ENG



## *Glow Easy • Glow +*

### *Versatility and design*

- Sliding system for wardrobes with 2, 3 or more overlapping doors
- Ideal for living room and bedroom applications
- Discrete and elegant application

### *Uncompromising performance*

- Controlled and decelerated opening and closing
- Smooth, soft and silent movement
- No resistance during sliding
- Compatible with wooden and aluminium doors
- Load capacity up to 70 kg per door, with strengthening kit available for doors up to 100 kg

### *Quick installation*

- Fast and intuitive assembly
- Fixing with screws or press-fit clips (Klik)



# *Glow Easy • Glow +*

## *Versatility and design*

Glow Easy and Glow+ are sliding systems for wardrobes with 2, 3 or more overlapping doors, developed for bedroom and living room applications. The smoothness of movement combines with discreet integration into the furniture, ensuring a clean and essential aesthetic result.

## *Uncompromising performance*

Glow Easy features an oil damper that ensures functional deceleration and user comfort during both opening and closing. The system is compatible with wooden and aluminium doors, with a load capacity up to 70 kg per door, extendable up to 100 kg with a dedicated strengthening kit, while maintaining high performance over time.

The innovative magnetic damping system of Glow+ ensures controlled deceleration during both opening and closing, delivering extremely smooth and silent sliding. The absence of resistance eliminates noise and significantly improves user comfort.

## *Quick installation*

Glow Easy and Glow+ are designed to offer maximum ease of installation, which can be carried out using press-fit clips (Klik) for fast and precise assembly, or with screws to reduce space requirements.



## Technical information

### FEATURES OF THE MECHANISM

- Aluminium profiles: alloy 6060T5, anodised silver.
- Sliding wheels: high speed bearings.
- Top and bottom carriages: painted sheet metal.
- Internal components: plastic and zamak.

### DOOR FEATURES

- Max. weight for each door 70 kg.  
With strengthening kit 100 kg. (evenly distributed).
- Thickness divided into 6 categories:
  - 1: up to 23 mm;
  - 2: up to 26 mm;
  - 3: up to 30 mm;
  - 4: up to 35 mm;
  - 5: up to 40 mm;
  - 6: up to 50 mm.
- Height from the ground: 17 mm or 33 mm.
- Material:
  - a) wood or wood-based material;
  - b) glass with metal frame.

### Minimum width for single Glow Easy door:

- 2 doors 600 mm;
- 3 doors 670 mm;
- 2 and 3 doors with strengthening kit 1000 mm.

### Minimum width for single Glow+ door:

- 2 doors 600 mm;
- 3 doors 830 mm;
- 2 and 3 doors with strengthening kit 1000 mm.

- Door adjustment: vertical +5/-0 mm.

### TYPES OF OPENING

Available in one, two, three or more doors, each ped both during opening and closing.

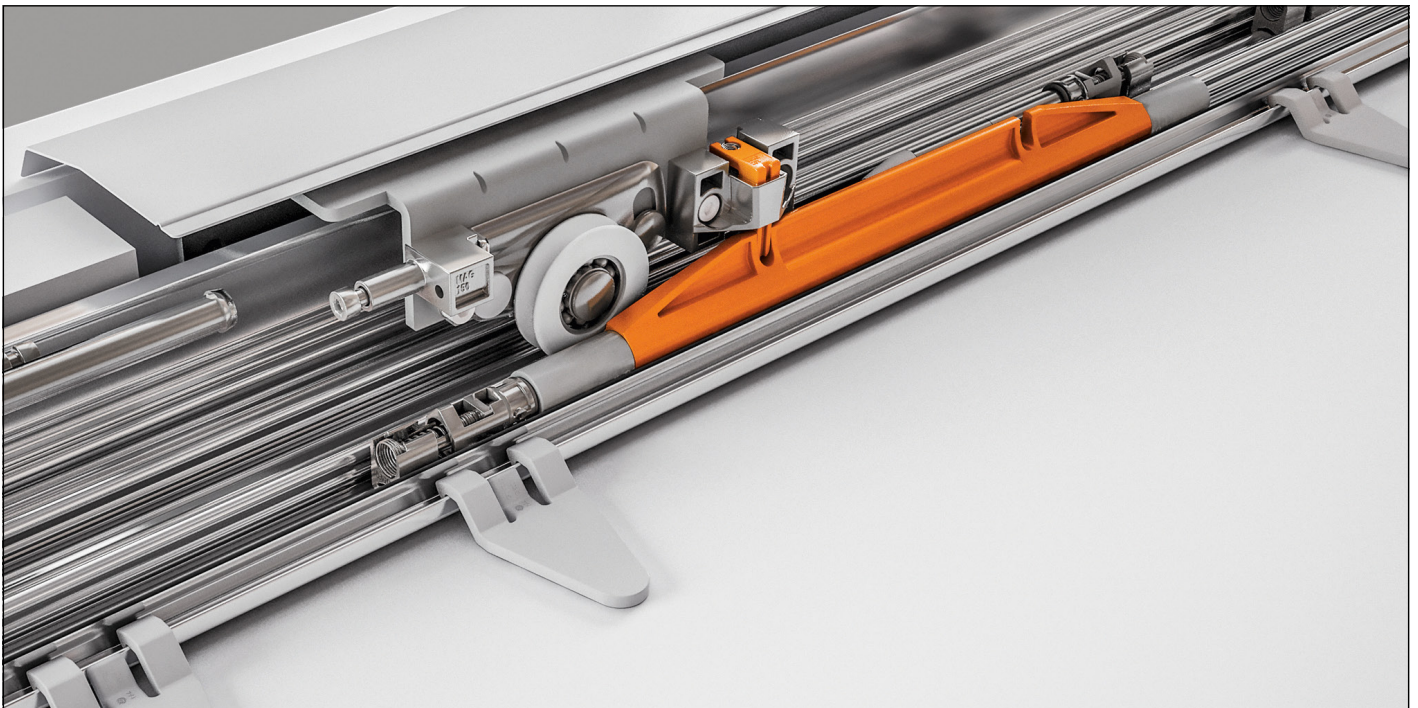

# Glow Easy

Key features

Door deceleration during opening and closing with oil damper.

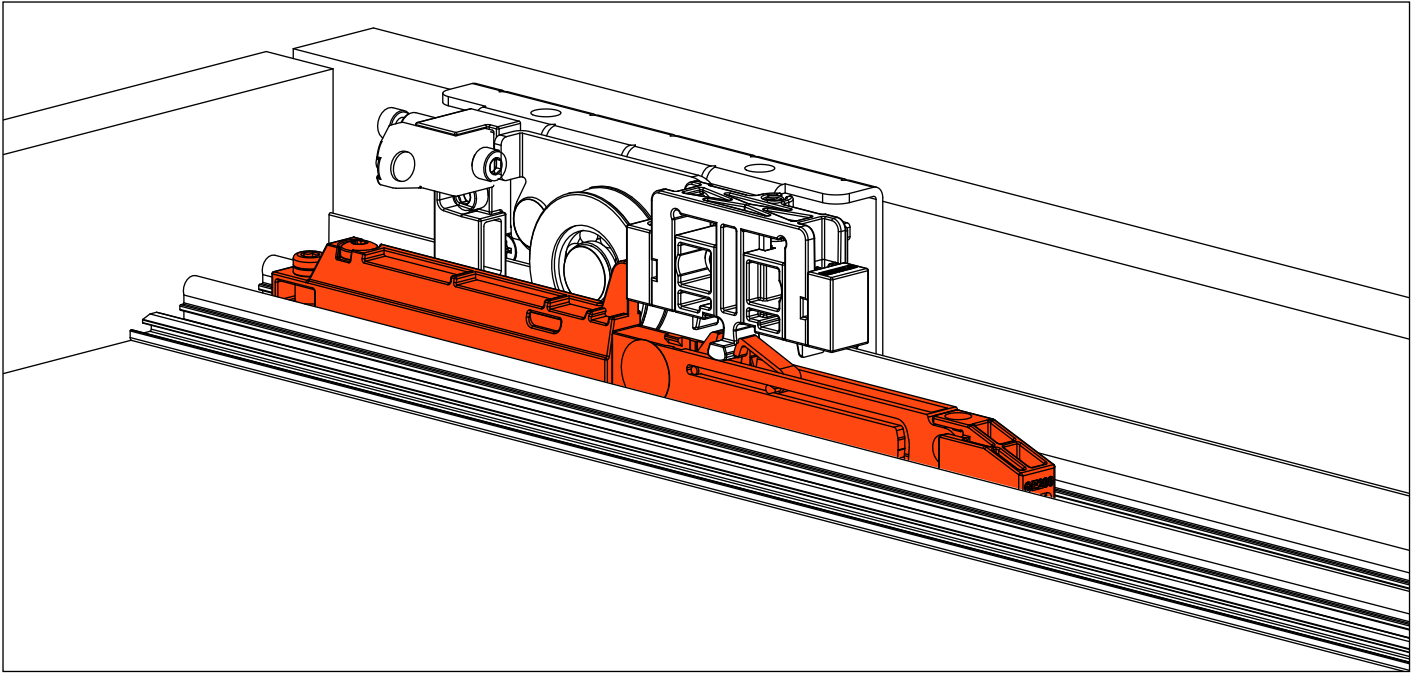

Stops that are extremely easy to fit and position.

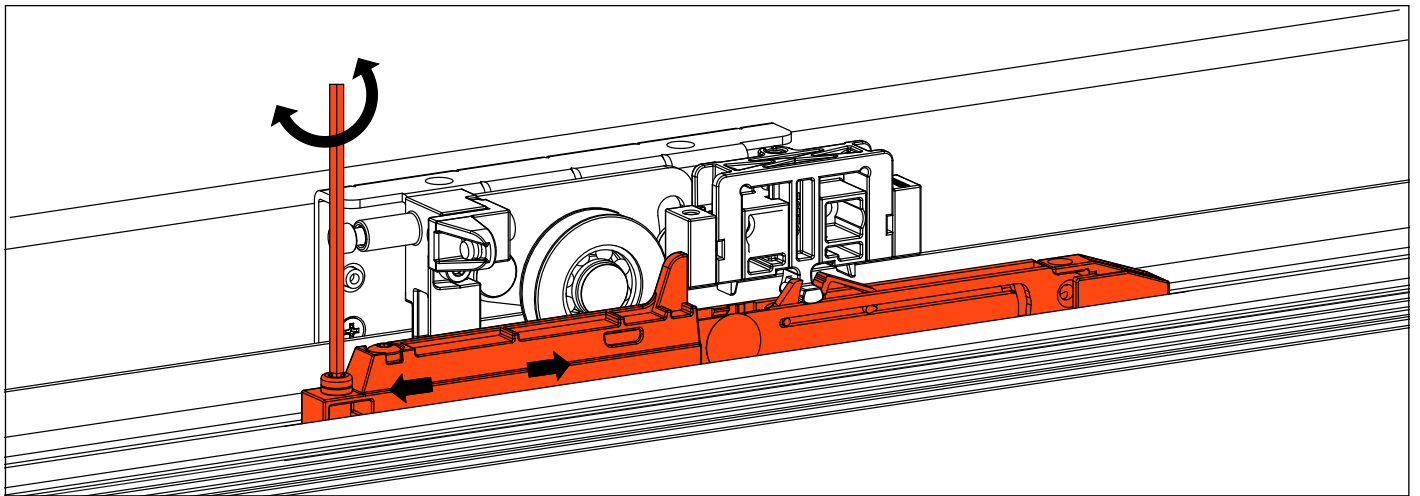

Automatic engage and release of the carriage and buffer.

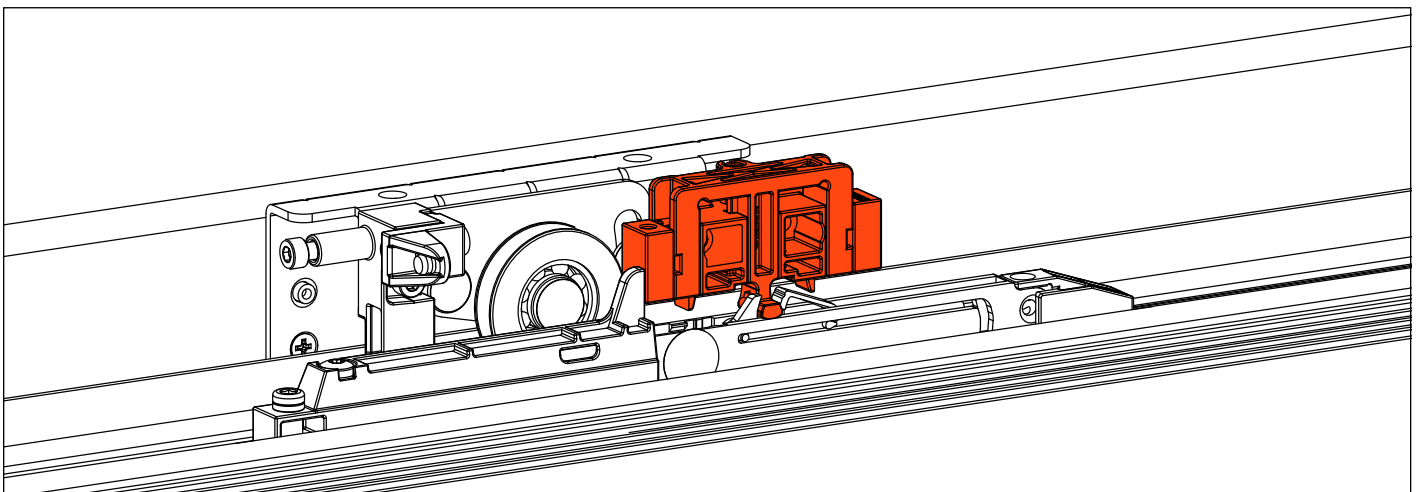

**Glow+**  
Key features

Innovative magnetic damper, ensuring smooth and silent movement.

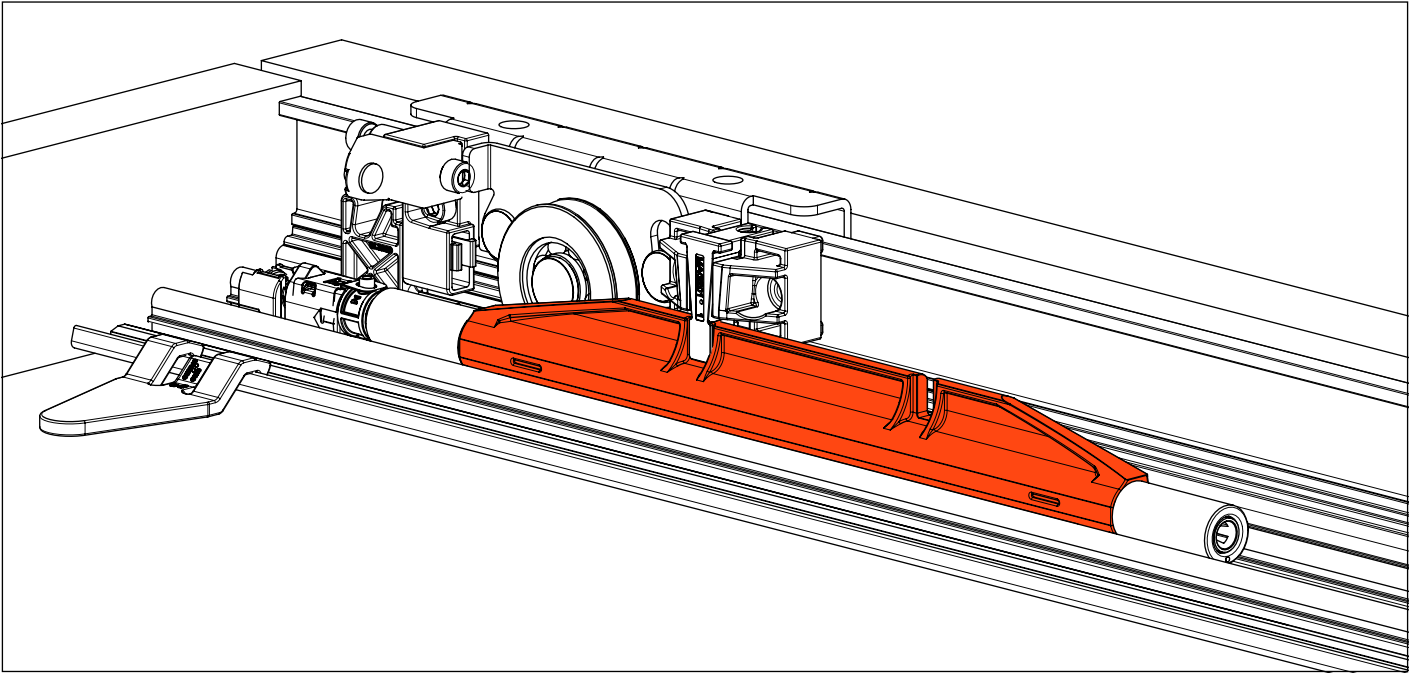

Stops that are extremely easy to fit and position.

Automatic engage and release of the carriage and buffer.

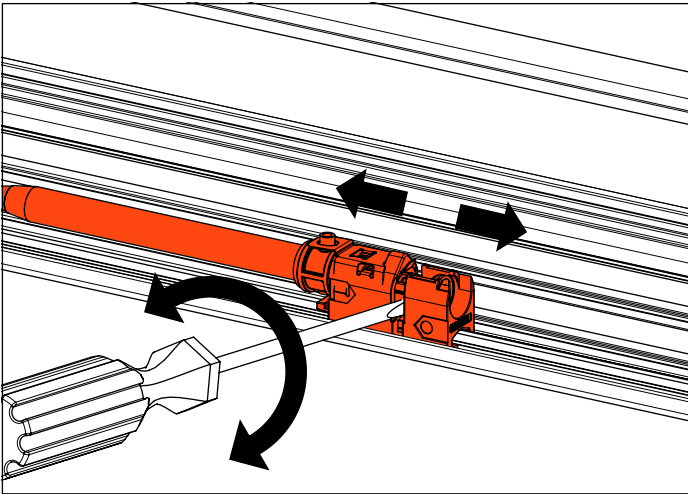

Front cover for the mechanism retained by magnets.

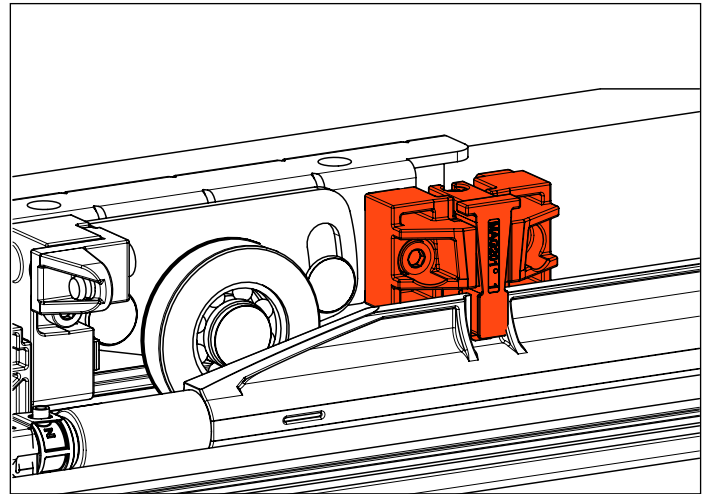

Guide tracks installed with press-fit clips.

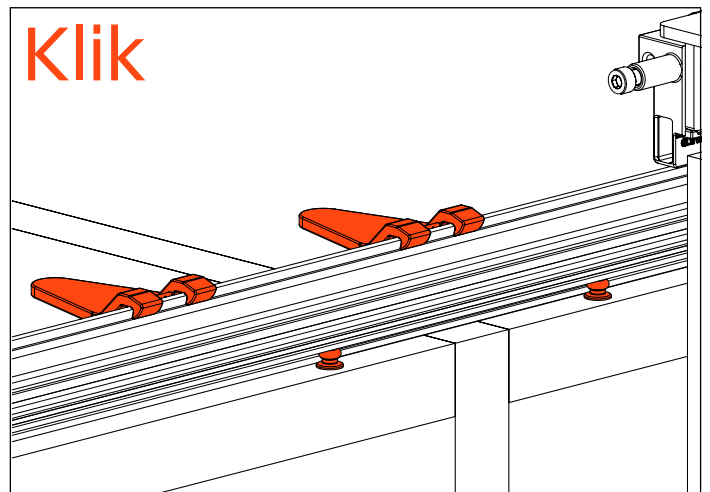
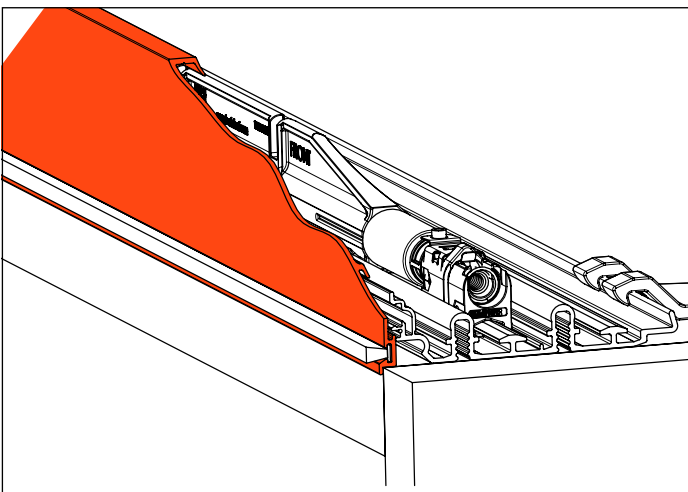

**Glow Easy • Glow+**  
Types of assembly

**Screw fixing**

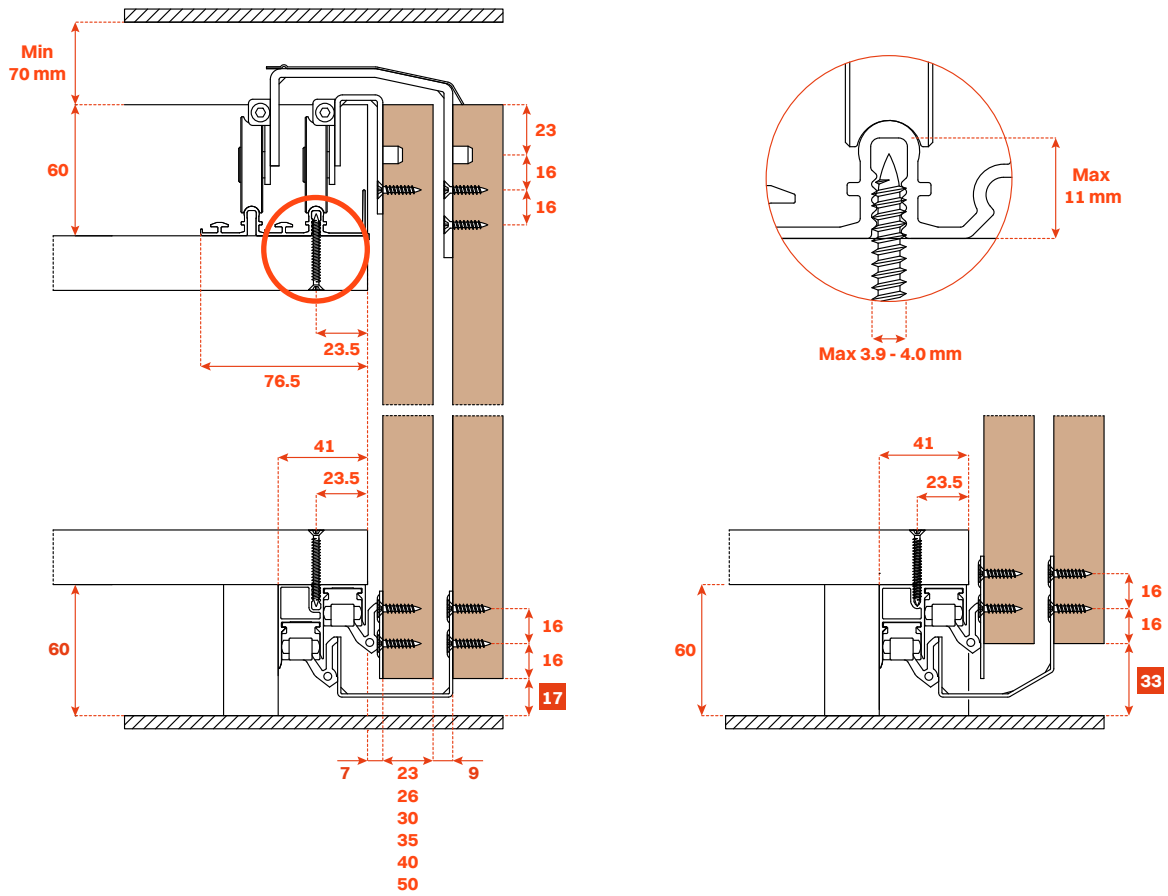

**Clip fixing**

**Klik**

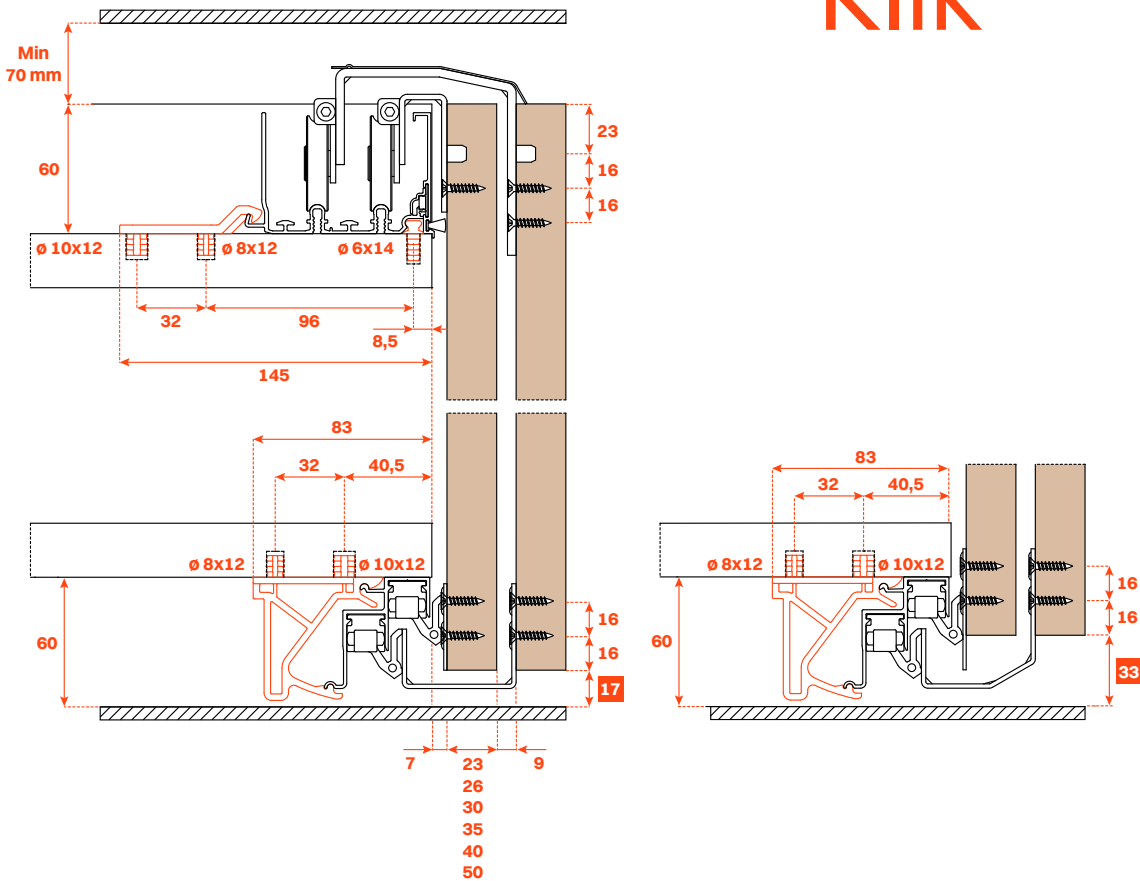

# Door machining operations

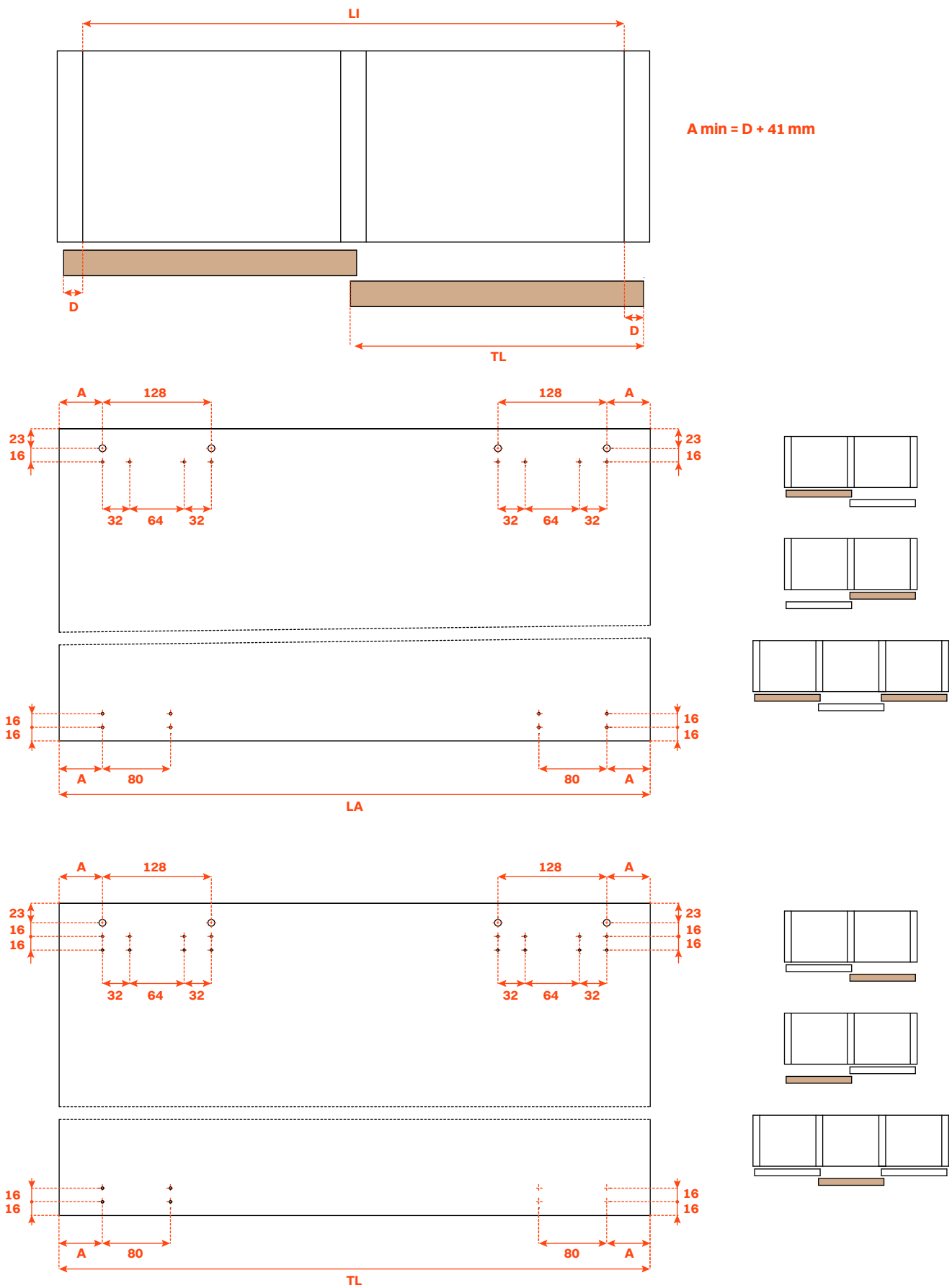



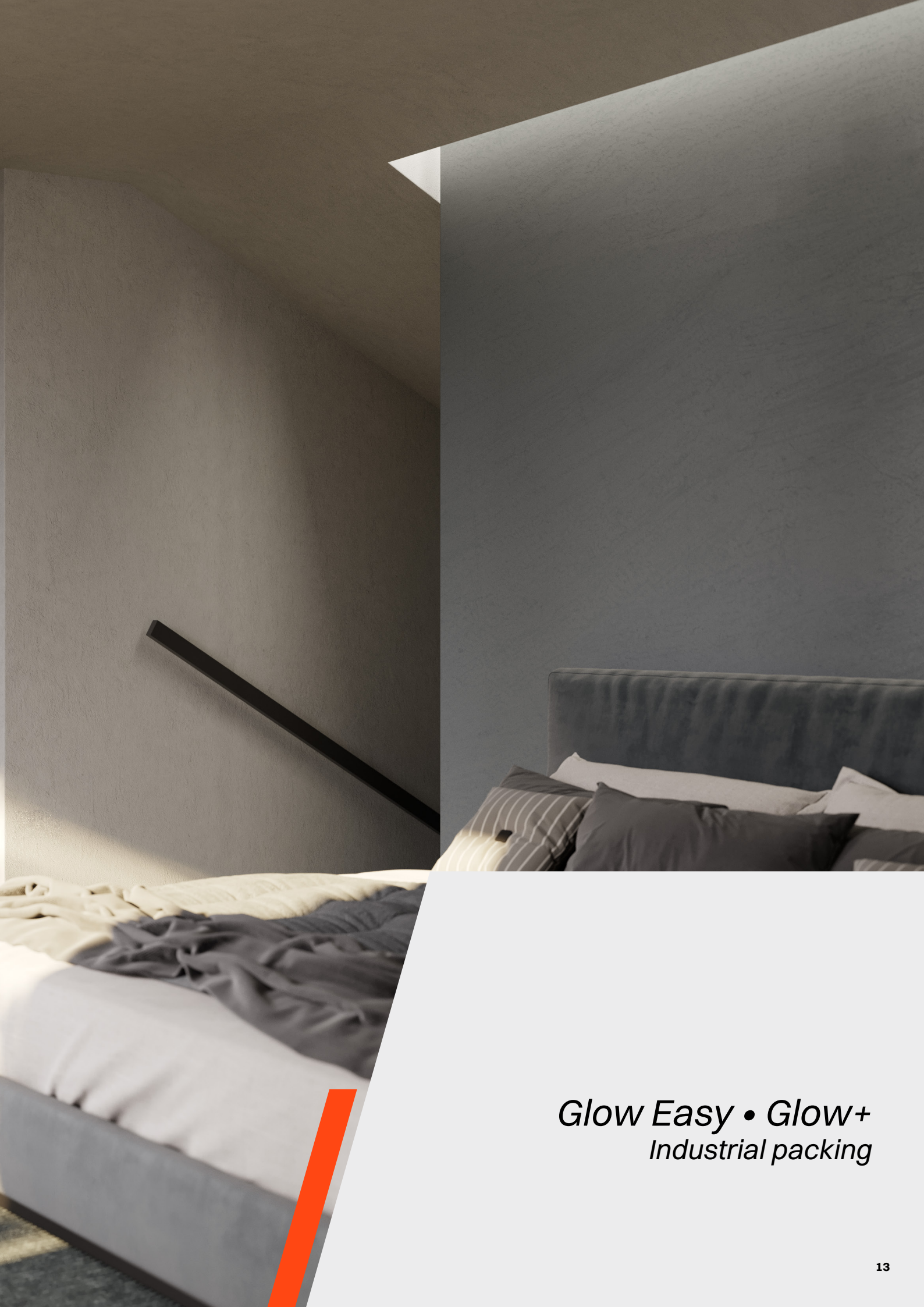





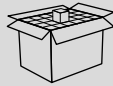







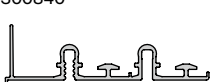



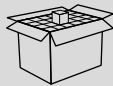

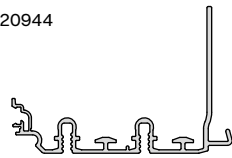

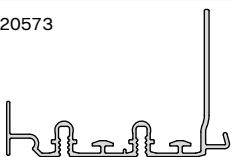

*Glow Easy • Glow+  
Industrial packing*

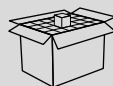
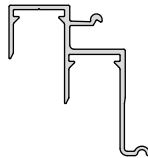

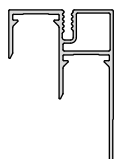
**Glow Easy • Glow+**  
Profiles

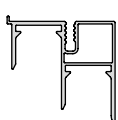
Standard upper profiles	L	Part number		Fixing	
	mm				
Designed for front cover	6200	VE41PIA16200AB	8	<b>Klik</b> 	21152 
	3100	VE41PTA13100AB	8	<b>Klik</b> 	
Not designed for front cover	6200	VE41PIB16200AB	8	<b>Klik</b> 	21151 
	3100	VE41PTB13100AB	8	<b>Klik</b> 	
Not designed for front cover	6200	VE41PIB36200AB	8		300840 
	3100	VE41PTB33100AB	8		





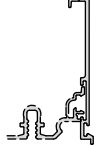
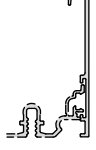
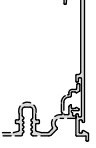

Reinforced upper profile	L	Part number		Fixing	
	mm				
Designed for front cover	6200	VE41PIA26200AB	8	<b>Klik</b> 	20944 
	3100	VE41PTA23100AB	8	<b>Klik</b> 	
Not designed for front cover	6200	VE41PIB26200AB	8	<b>Klik</b> 	20573 
	3100	VE41PTB23100AB	8	<b>Klik</b> 	

Lower profile	L	Part number		Fixing	
	mm				
	6200	VE41BIX06200AB	8	<b>Klik</b>	39428 
	3100	VE41BTX03100AB	8	<b>Klik</b>	
	6200	VE41PIE16200AB	8		21162 
	3100	VE41PTE13100AB	8		
	6200	VE41PIE26200AB	8		300841 
	3100	VE41PTE23100AB	8		













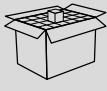

## Cover profiles













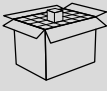

Front cover	L 	Part number	 pcs	
	mm			
With housing for brush, aluminium finish	6200	<b>VE41BIA06200AB</b>	8	34032 
	3100	<b>VE41BTA03100AB</b>	8	
Without housing for brush, finitura alluminio	6200	<b>VE41BIB06200AB</b>	8	35510 
	3100	<b>VE41BTB03100AB</b>	8	
With housing for brush, titanium finish	6200	<b>VE41BIA06200SB</b>	8	34032 
	3100	<b>VE41BTA03100SB</b>	8	

## Internal door sliding carriages

Article	 mm	Part number	 pcs	
Upper right carriage		<b>VE41KMCM1350DX0</b>	30	
Upper left carriage		<b>VE41KMCM1350SX0</b>	30	
Lower carriage	17	<b>VE41KMGLW310</b>	30	
	33	<b>VE41KMGLW320</b>	30	

**Glow Easy • Glow+**  
External door sliding carriages



Article	 mm	 mm	Part number	 pcs.	
Upper right carriage	≤ 23		<b>VE41KMCM1370DX0</b>	30	
Upper left carriage	≤ 23		<b>VE41KMCM1370SX0</b>	30	
Lower carriage	≤ 23	17	<b>VE41KMGLW311</b>	30	
	≤ 23	33	<b>VE41KMGLW321</b>	30	
Upper right carriage	≤ 26		<b>VE41KMCM1375DX0</b>	30	
Upper left carriage	≤ 26		<b>VE41KMCM1375SX0</b>	30	
Lower carriage	≤ 26	17	<b>VE41KMGLW316</b>	30	
	≤ 26	33	<b>VE41KMGLW326</b>	30	
Upper right carriage	≤ 30		<b>VE41KMCM1371DX0</b>	30	
Upper left carriage	≤ 30		<b>VE41KMCM1371SX0</b>	30	
Lower carriage	≤ 30	17	<b>VE41KMGLW312</b>	30	
	≤ 30	33	<b>VE41KMGLW322</b>	30	

Article	 mm	 mm	Part number		
Upper right carriage	≤ 35		<b>VE41KMCM1372DX0</b>	30	
Upper left carriage	≤ 35		<b>VE41KMCM1372SX0</b>	30	
Lower carriage	≤ 35	17	<b>VE41KMGLW313</b>	30	
	≤ 35	33	<b>VE41KMGLW323</b>	30	
Upper right carriage	≤ 40		<b>VE41KMCM1374DX0</b>	30	
Upper left carriage	≤ 40		<b>VE41KMCM1374SX0</b>	30	
Lower carriage	≤ 40	17	<b>VE41KMGLW315</b>	30	
	≤ 40	33	<b>VE41KMGLW325</b>	30	
Upper right carriage	≤ 50		<b>VE41KMCM1373DX0</b>	30	
Upper left carriage	≤ 50		<b>VE41KMCM1373SX0</b>	30	
Lower carriage	≤ 50	17	<b>VE41KMGLW314</b>	30	
	≤ 50	33	<b>VE41KMGLW324</b>	30	

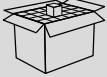
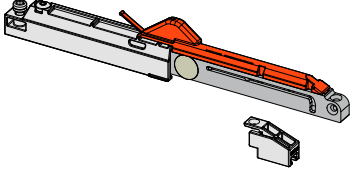
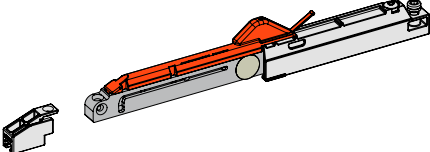
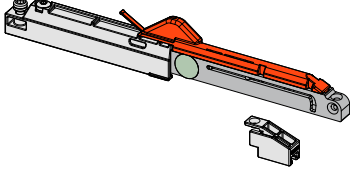
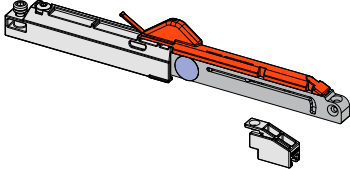
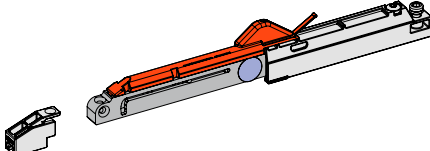
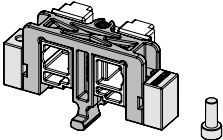
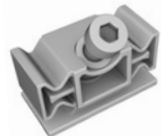

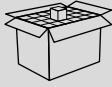
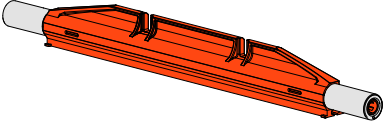
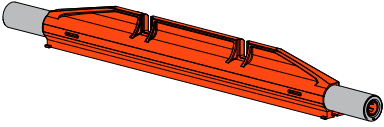
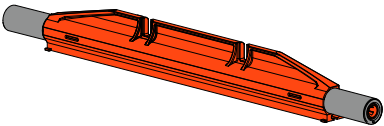
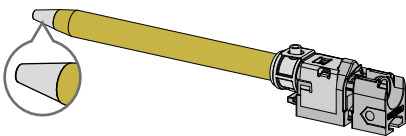
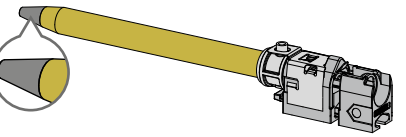
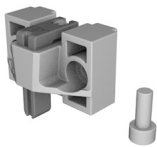

**Glow Easy**  
Shock absorber and stoppers

Article	Part number	 pcs.	
Easy right damper MAX 30 Kg	<b>VE41KGEAMMR02B</b>	30	
Easy left damper MAX 30 Kg	<b>VE41KGEAMML03B</b>	30	
AEasy right damper 30 - 50 Kg	<b>VE41KGEAMMR04B</b>	30	
Easy left damper 30 - 50 Kg	<b>VE41KGEAMML05B</b>	30	
Easy right damper 50 - 70 Kg	<b>VE41KGEAMMR06B</b>	30	
Easy left damper 50 - 70 Kg	<b>VE41KGEAMML07B</b>	30	
Activator for Easy dampers	<b>VE41KGEAMM001B</b>	30	
Bottom stop	<b>VE41KMGLW220</b>	60	



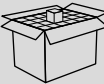

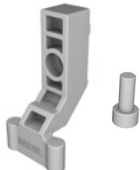



**Glow+**  
Shock absorber and stoppers

Article	Part number	 pcs.	
Magnetic damper 25 kg max.	<b>VE41KMAMCMA0500</b>	30	
Magnetic damper 25 - 45 kg	<b>VE41KMAMCMA1000</b>	30	
Magnetic damper 45 - 70 kg	<b>VE41KMAMCMA2000</b>	30	
Stop for magnetic damper 25 max and 25 - 45 kg	<b>VE41KMAMCMA5000</b>	60	
Stop for magnetic damper 45 - 70 kg	<b>VE41KMAMCMA5100</b>	60	
Pull for magnetic damper	<b>VE41KMAMCMA3000</b>	30	
Bottom stop	<b>VE41KMGLW220</b>	60	

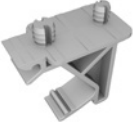
**Glow Easy • Glow+**  
*Non-damped stops*

Article	Part number	 pcs.	
Final stop	<b>VE41KMANCMI2000</b>	60	
Activator for final stop	<b>VE41KMANCMI3000</b>	30	
Bottom stop	<b>VE41KMGLW220P</b>	60	

Accessories









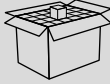

Article	Part number	 pcs.	
Frontal pin	<b>VE41MPGLW160</b>	180	
Upper clip	<b>VE41MPGLW260</b>	180	
Lower clip	<b>VE41MPGLW270.0</b>	180	
Lower clip applicator	<b>VE41MPGLW271.0</b>	30	
Back plate	<b>VE41MPGLW330</b>	200	
Magnet 25x6	<b>VE41MPMA250603</b>	200	
Gray brush H7	<b>VE41MPPB4829</b>	325 m	
Set of anti-derailment devices (Right+Left)	<b>VE41MPGLW280</b>	30	
Anti-collision pin	<b>VE41KMGLW510</b>	30	
Handle protector	<b>VE41KMGLW230</b>	30	







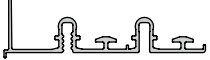



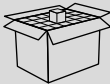

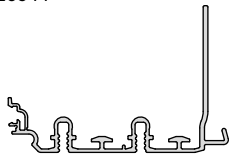

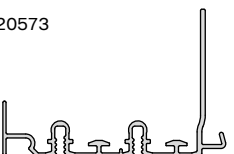

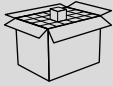

*Glow Easy • Glow+  
Kit packing*

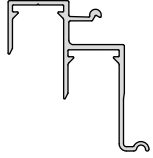
**Glow Easy • Glow+**  
Profiles

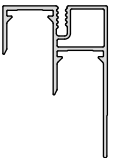

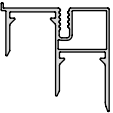

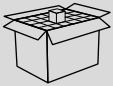
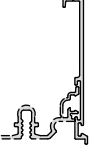
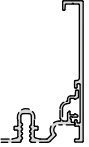
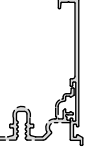

Standard upper profiles		Part number	 pcs.	Fixing	
	mm				
Designed for front cover	6200	<b>VE41PIA16200AB</b>	8	<b>Klik</b> 	21152 
	3100	<b>VE41PTA13100AB</b>	8	<b>Klik</b> 	
Not designed for front cover	6200	<b>VE41PIB16200AB</b>	8	<b>Klik</b> 	21151 
	3100	<b>VE41PTB13100AB</b>	8	<b>Klik</b> 	
Not designed for front cover	6200	<b>VE41PIB36200AB</b>	8		300840 
	3100	<b>VE41PTB33100AB</b>	8		

Reinforced upper profile		Part number	 pcs.	Fixing	
	mm				
Designed for front cover	6200	<b>VE41PIA26200AB</b>	8	<b>Klik</b> 	20944 
	3100	<b>VE41PTA23100AB</b>	8	<b>Klik</b> 	
Not designed for front cover	6200	<b>VE41PIB26200AB</b>	8	<b>Klik</b> 	20573 
	3100	<b>VE41PTB23100AB</b>	8	<b>Klik</b> 	





Lower profile	L	Part number		Fixing	
	mm				
	6200	<b>VE41BIX06200AB</b>	8	<b>Klik</b> 	39428 
	3100	<b>VE41BTX03100AB</b>	8	<b>Klik</b> 	
	6200	<b>VE41PIE16200AB</b>	8		21162 
	3100	<b>VE41PTE13100AB</b>	8		
	6200	<b>VE41PIE26200AB</b>	8		300841 
	3100	<b>VE41PTE23100AB</b>	8		

Front cover	L	Part number			
	mm				
With housing for brush, aluminum finish	6200	<b>VE41BIA06200AB</b>	8		34032 
	3100	<b>VE41BTA03100AB</b>	8		
Without housing for brush, aluminum finish	6200	<b>VE41BIB06200AB</b>	8		35510 
	3100	<b>VE41BTB03100AB</b>	8		
With housing for brush, titanio finish	6200	<b>VE41BIA06200SB</b>	8		34032 
	3100	<b>VE41BTA03100SB</b>	8		





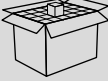

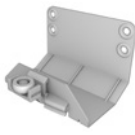

Carriage kit for cabinet with single internal door

Article	 mm	 mm	Part number	 pcs.	
Internal carriages for cabinet with single door	-	17	<b>VE41KSKSGE1090</b>	1	 <b>x 1</b>  <b>x 1</b>
	-	33	<b>VE41KSKSGE1590</b>	1	 <b>x 2</b>

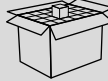

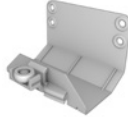







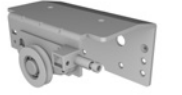
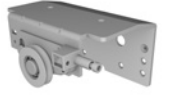

Carriage kit for cabinet with single external door

Article	 mm	 mm	Part number	 pcs.	
External carriages for cabinet with single door	≤ 23	17	<b>VE41KSKSGE1010</b>	1	 <b>x 1</b>
	≤ 23	33	<b>VE41KSKSGE1510</b>	1	 <b>x 1</b>
	≤ 30	17	<b>VE41KSKSGE1020</b>	1	 <b>x 2</b>
	≤ 30	33	<b>VE41KSKSGE1520</b>	1	











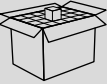
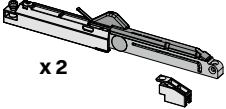

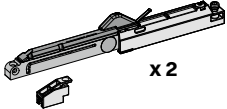

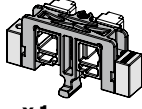

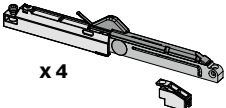

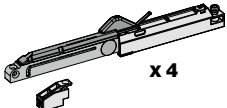

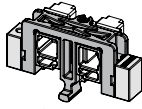

Carriage kit for 2-door cabinet

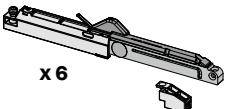
Article	 mm	 mm	Part number	 pcs.	
Carriages for 2-door cabinet	≤ 23	17	<b>VE41KSKSGE2010</b>	1	 x 1
	≤ 23	33	<b>VE41KSKSGE2510</b>	1	
	≤ 26	17	<b>VE41KSKSGE2060</b>	1	 x 1
	≤ 26	33	<b>VE41KSKSGE2560</b>	1	
	≤ 30	17	<b>VE41KSKSGE2020</b>	1	 x 2
	≤ 30	33	<b>VE41KSKSGE2520</b>	1	
	≤ 35	17	<b>VE41KSKSGE2030</b>	1	 x 1
	≤ 35	33	<b>VE41KSKSGE2530</b>	1	
	≤ 40	17	<b>VE41KSKSGE2040</b>	1	 x 1
	≤ 40	33	<b>VE41KSKSGE2540</b>	1	
	≤ 50	17	<b>VE41KSKSGE2050</b>	1	 x 2
	≤ 50	33	<b>VE41KSKSGE2550</b>	1	

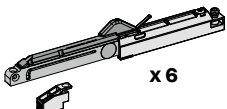

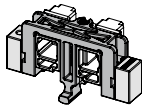







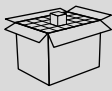







Carriage kit for 3-door cabinet

Article	 mm	 mm	Part number	 pcs.	
Carriages for 3-door cabinet	≤ 23	17	<b>VE41KSKSGE3010</b>	1	 x 1
	≤ 23	33	<b>VE41KSKSGE3510</b>	1	 x 1
	≤ 26	17	<b>VE41KSKSGE3060</b>	1	 x 1
	≤ 26	33	<b>VE41KSKSGE3560</b>	1	 x 1
	≤ 30	17	<b>VE41KSKSGE3020</b>	1	 x 2
	≤ 30	33	<b>VE41KSKSGE3520</b>	1	 x 2
	≤ 35	17	<b>VE41KSKSGE3030</b>	1	 x 2
	≤ 35	33	<b>VE41KSKSGE3530</b>	1	 x 2
	≤ 40	17	<b>VE41KSKSGE3040</b>	1	 x 2
	≤ 40	33	<b>VE41KSKSGE3540</b>	1	 x 2
	≤ 50	17	<b>VE41KSKSGE3050</b>	1	 x 4
	≤ 50	33	<b>VE41KSKSGE3550</b>	1	 x 4

**Glow Easy**  
Oil dampers kit

Article	Doors	 Door weight	Part number	 pcs.	
Dampers for 1-, 2- or 3-door cabinet	1	Max 30 Kg	<b>VE41KSAMGE1010</b>	1	 x 2 
	1	30 - 50 Kg	<b>VE41KSAMGE1020</b>	1	 x 2 
	1	50 - 70 Kg	<b>VE41KSAMGE1030</b>	1	 x 1  x 1  x 2
	2	Max 30 Kg	<b>VE41KSAMGE2010</b>	1	 x 4 
	2	30 - 50 Kg	<b>VE41KSAMGE2020</b>	1	 x 4 
	2	50 - 70 Kg	<b>VE41KSAMGE2030</b>	1	 x 2  x 3  x 1  x 4
	3	Max 30 Kg	<b>VE41KSAMGE3010</b>	1	 x 6 
	3	30 - 50 Kg	<b>VE41KSAMGE3020</b>	1	 x 6 
	3	50 - 70 Kg	<b>VE41KSAMGE3030</b>	1	 x 3  x 4  x 1  x 4

**Glow+**  
Magnetic dampers kit

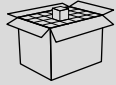
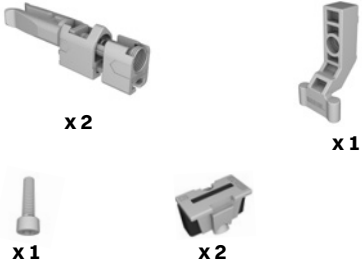
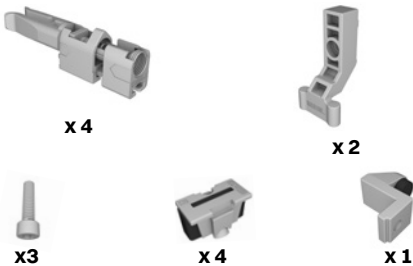
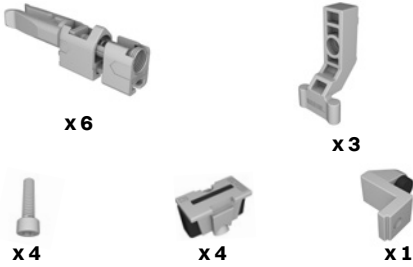

Article	Doors	 Door weight	Part number	 pcs.	
Dampers for 1-, 2- or 3-door cabinet	1	Max 25 Kg	<b>VE41KSAMGP4010</b>	1	 x 1
	1	25 - 45 Kg	<b>VE41KSAMGP4020</b>	1	 x 2
	1	45 - 70 Kg	<b>VE41KSAMGP4030</b>	1	 x 2  x 1  x 1
	2	Max 25 Kg	<b>VE41KSAMGP5010</b>	1	 x 2
	2	25 - 45 Kg	<b>VE41KSAMGP5020</b>	1	 x 4  x 4
	2	45 - 70 Kg	<b>VE41KSAMGP5030</b>	1	 x 3  x 2  x 1
	3	Max 25 Kg	<b>VE41KSAMGP6010</b>	1	 x 3
	3	25 - 45 Kg	<b>VE41KSAMGP6020</b>	1	 x 6  x 4
	3	45 - 70 Kg	<b>VE41KSAMGP6030</b>	1	 x 4  x 3  x 1

**Glow Easy • Glow+**  
*Non-damped kit*

Article	Doors	Part number	 pcs.	
Stops for 1-, 2- or 3-door cabinet	1	<b>VE41KSNAGE7000</b>	1	
	2	<b>VE41KSNAGE8000</b>	1	
	3	<b>VE41KSNAGE9000</b>	1	

## Glow Easy • Glow

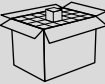
100 Kg Carriage kit • A pair of carriages, which in addition to the standard ones, increase the weight capacity of the system up to max. 100 kg per door.

Article	Part number	 pcs.	
Internal door carriages	VE41KSKPCMI1A99	1	 x1                      x1

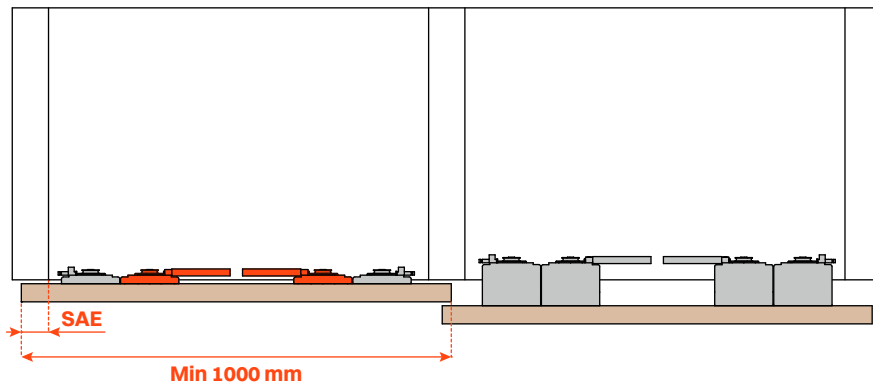
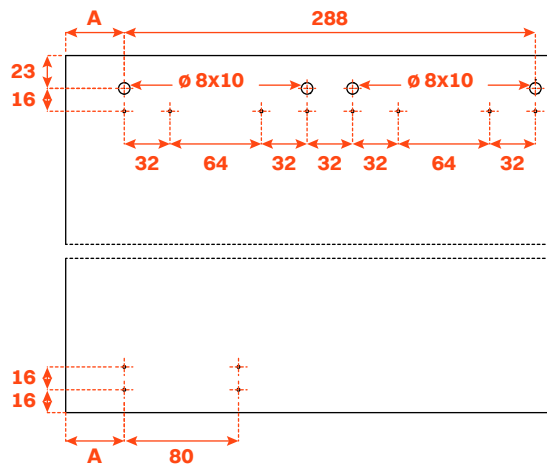



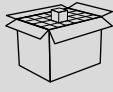
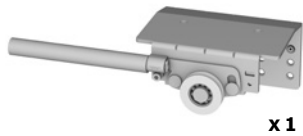
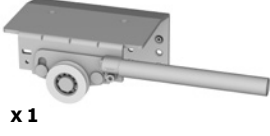

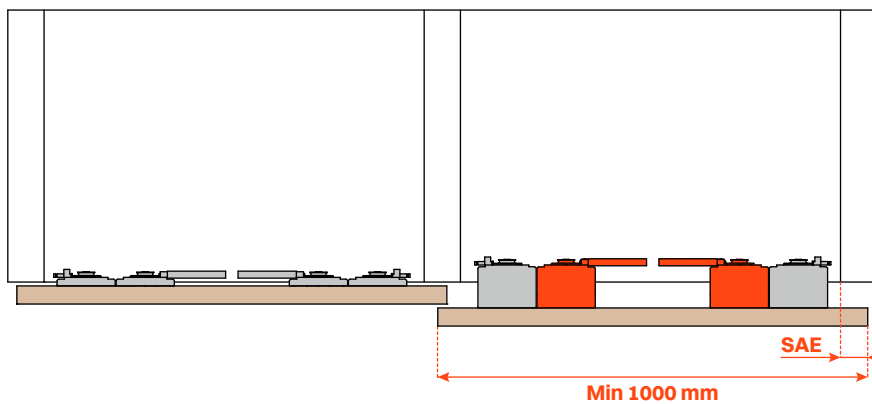
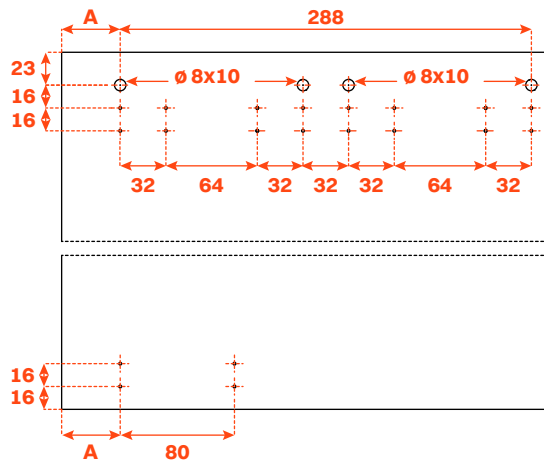



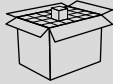

**A min = SAE + 41 mm**

Article	 mm	Part number	 pcs.	
External door carriages	23	VE41KSKPCMI1A19	1	 x 1   x 1
	26	VE41KSKPCMI1A69	1	
	30	VE41KSKPCMI1A29	1	
	35	VE41KSKPCMI1A39	1	
	40	VE41KSKPCMI1A49	1	
	50	VE41KSKPCMI1A59	1	









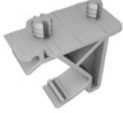

**A min = SAE + 41 mm**

Front cover accessories kit

Article	L	Part number	 pcs.	
	mm			
<i>Kit of magnets, back plates and brush</i>	≤ 2000	<b>VE41KSM0S05</b>	1	 x5  x5  x2
	≤ 3000	<b>VE41KSM0S06</b>	1	 x6  x6  x3
	≤ 4000	<b>VE41KSM0S07</b>	1	 x8  x8  x4

Kit clip

Article	Part number	 pcs.				
Set of 6 clips with applicator	<b>VE41KSCLIP6</b>	1	 <b>x 6</b>	 <b>x 6</b>	 <b>x 6</b>	 <b>x 1</b>
Set of 9 clips with applicator	<b>VE41KSCLIP9</b>	1	 <b>x 9</b>	 <b>x 9</b>	 <b>x 9</b>	 <b>x 1</b>

Klik

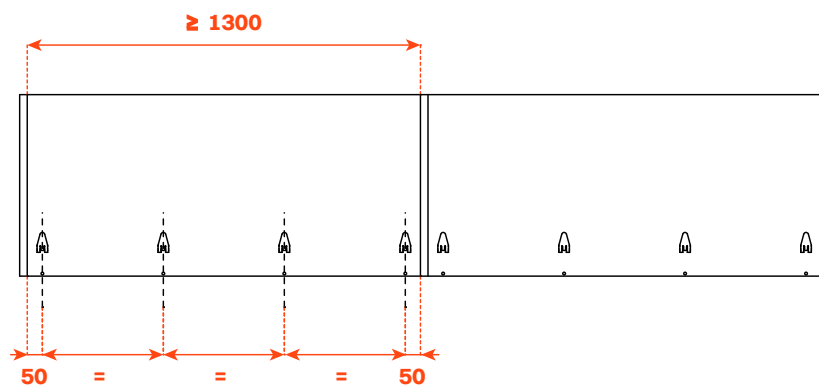
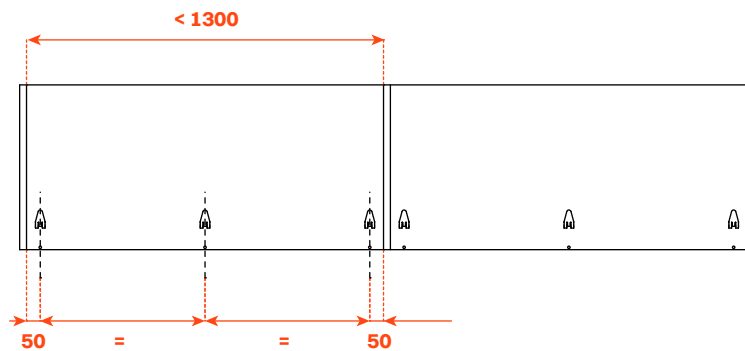

## Glow Easy • Glow+

Anti-collision pins kit • For 3-door cabinets, is possible to order anti-collision pins, to be applied to the internal door (1 kit of 2 pieces).

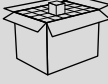
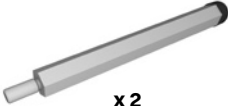
<b>Article</b>	<b>Part number</b>	 <b>pcs.</b>	
Anti-collision pins	<b>VE41KMGLW510C</b>	1	 <b>x 2</b>

Dust cover with self adhesive velcro

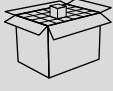
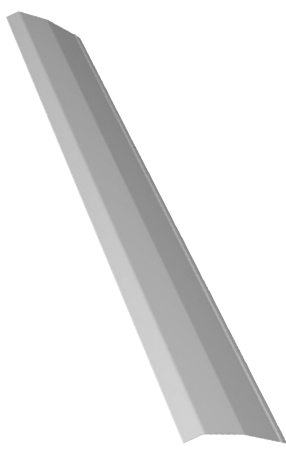
Article	L	Part number Black finish	Part number Grey finish	 pcs.	
	mm				
External door bracket cover	600	VE41CP0A001N3A	VE41CP0A001N6A	1	
	700	VE41CP0A002N3A	VE41CP0A002N6A		
	800	VE41CP0A003N3A	VE41CP0A003N6A		
	900	VE41CP0A004N3A	VE41CP0A004N6A		
	1000	VE41CP0A005N3A	VE41CP0A005N6A		
	1100	VE41CP0A006N3A	VE41CP0A006N6A		
	1200	VE41CP0A007N3A	VE41CP0A007N6A		
	1300	VE41CP0A008N3A	VE41CP0A008N6A		
	1400	VE41CP0A009N3A	VE41CP0A009N6A		
	1500	VE41CP0A010N3A	VE41CP0A010N6A		
	1600	VE41CP0A011N3A	VE41CP0A011N6A		
	1700	VE41CP0A012N3A	VE41CP0A012N6A		
	1800	VE41CP0A013N3A	VE41CP0A013N6A		
	1900	VE41CP0A014N3A	VE41CP0A014N6A		
	2000	VE41CP0A015N3A	VE41CP0A015N6A		
	600	VE41CP0A001N6A	VE41CP0A001N6B	10	
	700	VE41CP0A002N6A	VE41CP0A002N6B		
	800	VE41CP0A003N6A	VE41CP0A003N6B		
	900	VE41CP0A004N6A	VE41CP0A004N6B		
	1000	VE41CP0A005N6A	VE41CP0A005N6B		
	1100	VE41CP0A006N6A	VE41CP0A006N6B		
	1200	VE41CP0A007N6A	VE41CP0A007N6B		
	1300	VE41CP0A008N6A	VE41CP0A008N6B		
	1400	VE41CP0A009N6A	VE41CP0A009N6B		
	1500	VE41CP0A010N6A	VE41CP0A010N6B		
	1600	VE41CP0A011N6A	VE41CP0A011N6B		
	1700	VE41CP0A012N6A	VE41CP0A012N6B		
	1800	VE41CP0A013N6A	VE41CP0A013N6B		
	1900	VE41CP0A014N6A	VE41CP0A014N6B		
	2000	VE41CP0A015N6A	VE41CP0A015N6B		

## HEADQUARTERS AND PRODUCTION UNITS

---

### ARTURO SALICE S.p.A.

#### HEAD OFFICE

VIA PROVINCIALE NOVEDRATESE, 10  
22060 NOVEDRATE (COMO) ITALIA  
TEL. 031 790424 - FAX 031 791508  
info.salice@salice.com  
www.salice.com

#### ARTURO SALICE S.p.A.

VIA ARISTIDE MERLONI, 11  
61036 COLLI AL METAURO (PU) ITALIA  
TEL. 0721 899800  
FAX 0721 897980  
info.salice@salice.com  
www.salice.com

#### BORTOLUZZI SISTEMI S.p.A.

VIA CADUTI 14 SETTEMBRE 1944, 45  
32100 BELLUNO (BL) ITALIA  
TEL. 0437 930866  
FAX 0437 931442  
info@bortoluzzi.com  
www.salice.com

#### NUOVA ATIM S.r.l.

VIA IV NOVEMBRE, 52  
20019 SETTIMO MILANESE (MI) ITALIA  
TEL. 02 33503203  
FAX 02 33516514  
info@atimspa.com  
www.atimspa.com

#### VILLES S.r.l.

VIA CASTOLDI, 6/8  
20090 TREZZANO SUL NAVIGLIO (MI) ITALIA  
TEL. 02 4452083  
FAX 02 4452838  
info@villes2000.com  
www.villes2000.com

## BRANCHES

---

#### DEUTSCHE SALICE GMBH

RUDOLF DIESEL STR. 10  
74382 NECKARWESTHEIM  
TEL. 07133 9807-0  
FAX. 07133 9807-16  
info.salice@deutschesalice.de  
www.salice.com

#### DEUTSCHE SALICE GMBH

VERKAUFSBÜRO NORD  
RINGSTRASSE 36/A30 CENTER  
32584 LÖHNE  
TEL. 05731 15608-0  
FAX. 05731 15608-10  
vknord@deutschesalice.de  
www.salice.com

#### SALICE UK LTD.

KINGFISHER WAY  
HINCHINGBROOKE BUSINESS PARK  
HUNTINGDON CAMBS PE 29 6FN  
TEL. 01480 413831  
FAX. 01480 451489  
info.salice@saliceuk.co.uk  
www.salice.com

#### SALICE FRANCE S.A.R.L.

285 RUE DE GOA ZAC LES 3 MOULINS  
06600 ANTIBES  
TEL. 0493 330069  
FAX. 0493 330141  
info.salice@salicefrance.com  
www.salice.com

#### SALICE ESPAÑA, S.L.U.

C/ AIGUAFREDA 4, P.I. AMETLLA PARK  
08480 L'AMETLLA DEL VALLÈS (BARCELONA)  
TEL. 0034 938 46 88 61  
info.salice@saliceespana.es  
www.salice.com

#### SALICE PORTUGAL UNIP. LDA

**SHOWROOM:**  
TV SÁ E MELO 161 FA  
4470-116 MAIA - PORTO  
TEL: 00351 224 154 221  
Info@saliceportugal.pt  
www.salice.com

**ARMAZÉM:**  
VIA ROTA DOS MÓVEIS I 399  
4585-325 GANDRA

#### SALICE CHINA (SHANGHAI) CO. LTD.

RM 602, 6/F, TOWER 1,  
3688 YINGGANG DONG ROAD  
QINGPU DISTRICT  
201703 SHANGHAI, CHINA  
TEL. 021 3988-9880  
info.salice@salicechina.com  
www.salicechina.com

#### SALICE INDIA PVT. LTD.

1001 & 1002, 10TH FLOOR,  
CENTRUM, PLOT NO. C-3,  
OPP. WAGLE PRABHAG SAMITI OFFICE,  
MIDC AREA, WAGLE INDUSTRIAL ESTATE,  
THANE - 400604, MAHARASHTRA  
TEL. 022 20812050  
info@saliceindia.com  
www.salice.com

#### SALICE CANADA INC.

3500 RIDGEWAY DRIVE,  
UNIT#1  
MISSISSAUGA, ONTARIO, L5L 0B4  
TEL. 905 820 8787  
FAX. 905 820 7226  
info.salice@salicecanada.com  
www.salicecanada.com

#### SALICE AMERICA INC.

2123 CROWN CENTRE DRIVE  
CHARLOTTE NC. 28227  
TEL. 704 841 7810  
FAX. 704 841 7808  
info.salice@saliceamerica.com  
www.saliceamerica.com



# ARTURO SALICE S.p.A.

## HEAD OFFICE

VIA PROVINCIALE NOVEDRATESE, 10  
22060 NOVEDRATE (COMO) ITALIA  
TEL. 031 790424 - FAX 031 791508

info.salice@salice.com  
www.salice.com

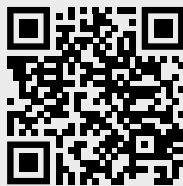

**Digital contents**

**We reserve the right to change technical specifications without notice.**

DOCASS004ENG Ed. 05 - 05/2026

