

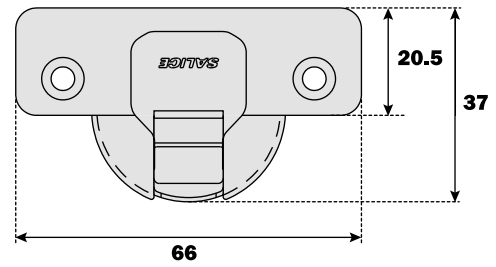

**Series 800**  
***SALICE***

**Bright nickel plated steel cup and arm.**  
**Dimensions of the Ø 35 mm cup.**



Approx. number of hinges required according to the door dimension and weight.

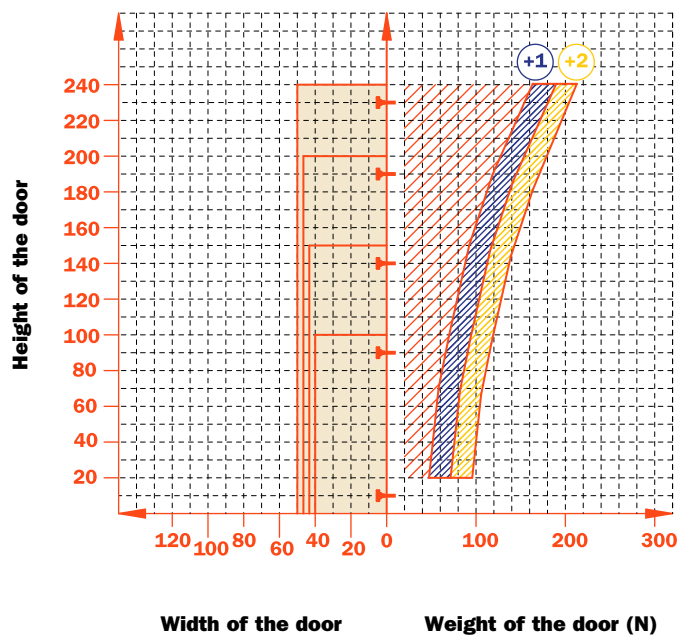

**Adjustments**





Side adjustment from -1.5 mm to +4.5 mm.  
 Height adjustment  $\pm 2$  mm.  
 Depth adjustment from -1.5 mm to +3 mm.

**Mounting plates**

Symmetrical and asymmetrical bright nickel plated steel Series 200 mounting plates.  
**NOT COMPATIBLE** with Series 200 die-cast mounting plates.

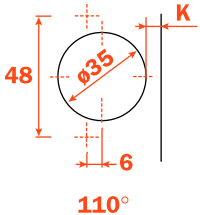
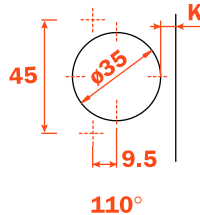
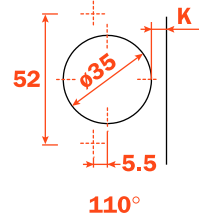
N.B. : Use POZIDRIVE No. 2 screwdrivers for all screws.

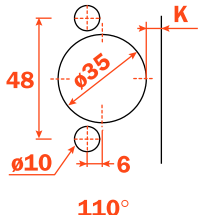
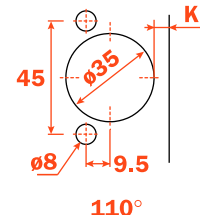
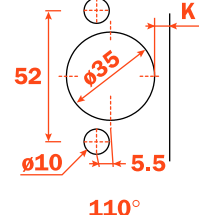
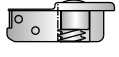
## Drillings and fixings

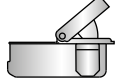
			
<b>Wood screw</b> 	<b>A</b>	<b>P</b>	<b>U</b>
			
<b>Rapido</b> 	<b>6</b>	<b>7</b>	<b>2</b>
<b>Dowel</b> 	<b>B</b>	<b>R</b>	<b>W</b>
<b>Logica</b> 	<b>I</b>	<b>J</b>	<b>Q</b>

Use this table to identify the available drillings and fixings.

Fill the third position of the hinge code number with the letter or the number corresponding to your choice. I.e.: C8\_6C99.

↑  
Fill this position with the chosen letter or number.



## Technical information

When a greater opening angle is required.  
 11 mm deep metal cup.  
 110° opening.  
 Possible drilling distance on the door (K): from 3 to 6 mm.  
 Compatible with all traditional steel Series 200 mounting plates.

## Space needed to open the door

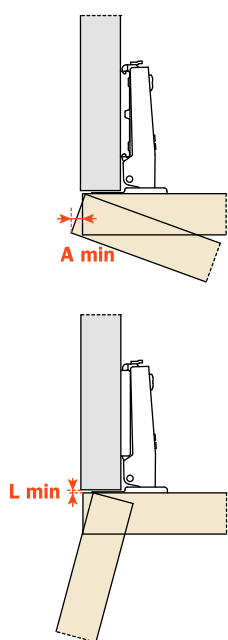

	T=	16	17	18	19	20	21	22	23	24	25	26
K=3	<b>A=</b>	0.5	0.7	0.9	1.2	1.5	1.8	2.4	3.7	5.1	6.5	7.8
K=4	<b>A=</b>	0.5	0.7	0.9	1.2	1.5	1.8	2.1	2.7	4.1	5.5	6.8
K=5	<b>A=</b>	0.5	0.7	0.9	1.2	1.5	1.8	2.1	2.6	3.1	4.1	5.4
K=6	<b>A=</b>	0.5	0.7	0.9	1.2	1.5	1.8	2.1	2.5	3.0	3.5	4.4

	T=	16	17	18	19	20	21	22	23	24	25	26
K=3	<b>L=</b>	0.0	0.0	0.0	0.0	0.2	0.5	0.8	1.1	1.4	1.7	1.9
K=4	<b>L=</b>	0.0	0.0	0.3	0.6	0.9	1.2	1.4	1.7	2.0	2.3	2.6
K=5	<b>L=</b>	1.1	1.3	1.6	1.8	2.1	2.3	2.6	2.9	3.1	3.4	3.6
K=6	<b>L=</b>	2.0	2.3	2.5	2.8	3.1	3.3	3.6	3.8	4.3	4.3	4.6

The above values are calculated on the assumption that the doors have square edges. They are reduced if the doors have radiused edges.

## Projection of the door

Projection of the door from the cabinet side at the max. opening. The figures are based on a straight arm hinge, H=0 mm thickness of mounting plate and K value = 3 mm.

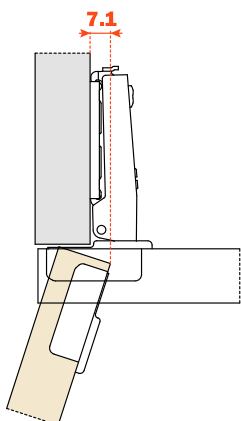

## "C" value

With this formula you can obtain the max. thickness of the moulded door that can be opened without touching adjacent carcass sides, doors or walls, whilst bearing in mind the above L-K-T values.

$$C = 20 + K + A$$

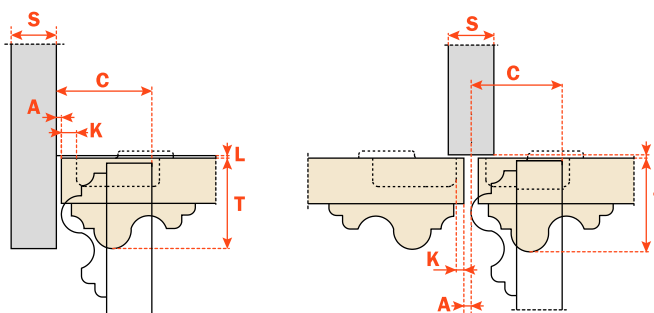

**Packing**

Boxes 300 pcs.  
Pallets 7.200 pcs.

**CA** sprung hinge  
**CL** unsprung hinge

Use these formulas to determine the type of hinge arm, the drilling distance "K" and the height of the mounting plate "H" which is necessary to solve each application problem.

Use the tables "Drillings and fixings" at page 3 to complete the code number of the desired hinge.

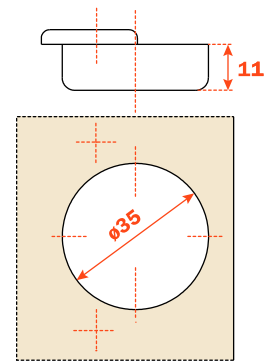
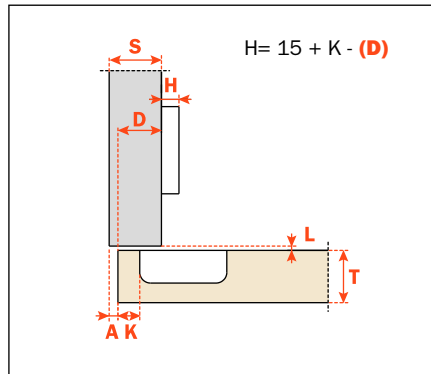
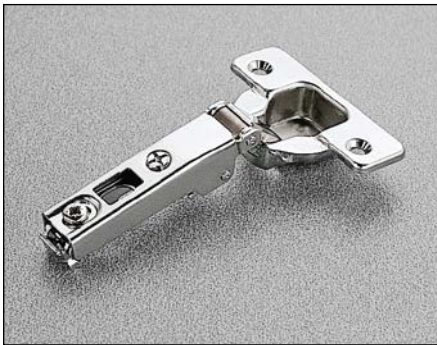
**Arm 0**

**CA - C8\_6C99**  
**CL - C8\_4C99**

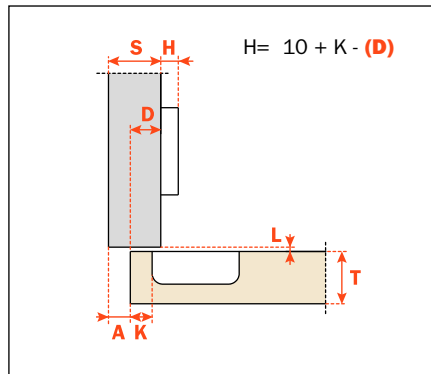
**Arm 5**

**CA - C8\_6J99**  
**CL - C8\_4J99**

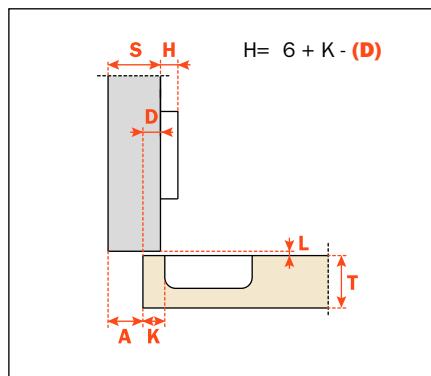
**Arm 9**

**CA - C8\_6L99**  
**CL - C8\_4L99**

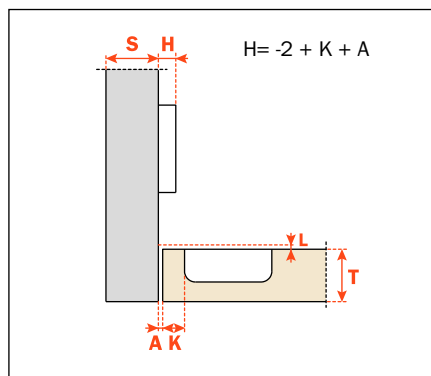
**Arm 17**

**CA - C8\_BS99**  
**CL - C8\_AS99**

**94° Opening**





**DEUTSCHE SALICE GMBH**

RUDOLF DIESEL STR. 10  
POSTFACH 1154  
74382 NECKARWESTHEIM  
TEL. 07233 9807-0  
FAX. 07233 9807-16  
info.salice@deutschesalice.de  
www.deutschesalice.de

**DEUTSCHE SALICE GMBH**

VERKAUFSBÜRO NORD  
RINGSTRASSE 36/A30 CENTER  
32584 LÖHNE  
TEL. 05731 15608-0  
FAX. 05731 15608-10  
vknord@deutschesalice.de  
www.deutschesalice.de

**SALICE FRANCE S.A.R.L.**

ROUTE DE GOA ZAC LES 3 MOULINS  
06600 ANTIBES  
TEL. 0493 330069  
FAX. 0493 330141  
info.salice@salicefrance.com  
www.salicefrance.com

**SALICE ESPAÑA, S.L.U.**

CALLE COPÉRNICO, 11  
POLÍGONO INDUSTRIAL  
COLL DE LA MANYA  
08403 GRANOLLERS (BARCELONA)  
TEL. 938 46 88 61  
FAX 938 49 11 97  
info.salice@saliceespana.es  
www.saliceespana.es

**SALICE UK LTD.**

KINGFISHER WAY  
HINCHINGBROOKE BUSINESS PARK  
HUNTINGDON CAMBS PE 29 6FN  
TEL. 01480 413831  
FAX. 01480 451489  
info.salice@saliceuk.co.uk  
www.saliceuk.co.uk

**SALICE AMERICA INC.**

2123 CROWN CENTRE DRIVE  
CHARLOTTE NC. 28227  
TEL. 704 8417810  
FAX. 704 8417808  
info.salice@saliceamerica.com  
www.saliceamerica.com

**SALICE CANADA INC.**

3500 RIDGEWAY DRIVE,  
UNIT#1  
MISSISSAUGA, ONTARIO, L5L 0B4  
TEL. 905 8208787  
FAX. 905 8207226  
info.salice@salicecanada.com  
www.salicecanada.com

**SALICE CHINA  
(SHANGHAI) CO. LTD.**

1st FLOOR, B1 BLDG 928 MINGZHU ROAD  
XUJING, QINGPU DISTRICT  
SHANGHAI 201702 - CHINA  
Tel. 021 3988 9880  
Fax 021 3988 9882  
info.salice@salicechina.com  
www.salicechina.com