

Technical information

FEATURES OF THE MECHANISM

- Aluminium profiles: alloy 6060T5, anodised silver.
- Sliding wheels: high speed bearings.
- Top and bottom carriages: painted sheet metal.
- Internal components: plastic and zamak.

DOOR FEATURES

- Max. weight for each door 70 kg.
With strengthening kit 100 kg. (evenly distributed).
- Thickness divided into 6 categories:
 - 1: up to 23 mm;
 - 2: up to 26 mm;
 - 3: up to 30 mm;
 - 4: up to 35 mm;
 - 5: up to 40 mm;
 - 6: up to 50 mm.
- Height from the ground: 17 mm or 33 mm.
- Material:
 - a) wood or wood-based material;
 - b) glass with metal frame.

Minimum width for single Glow Easy door:

- 2 doors 600 mm;
- 3 doors 670 mm;
- 2 and 3 doors with strengthening kit 1000 mm.

Minimum width for single Glow+ door:

- 2 doors 600 mm;
- 3 doors 830 mm;
- 2 and 3 doors with strengthening kit 1000 mm.

- Door adjustment: vertical +5/-0 mm.

TYPES OF OPENING

Available in one, two, three or more doors, each ped both during opening and closing.



Glow Easy

Key features

Door deceleration during opening and closing with oil damper.

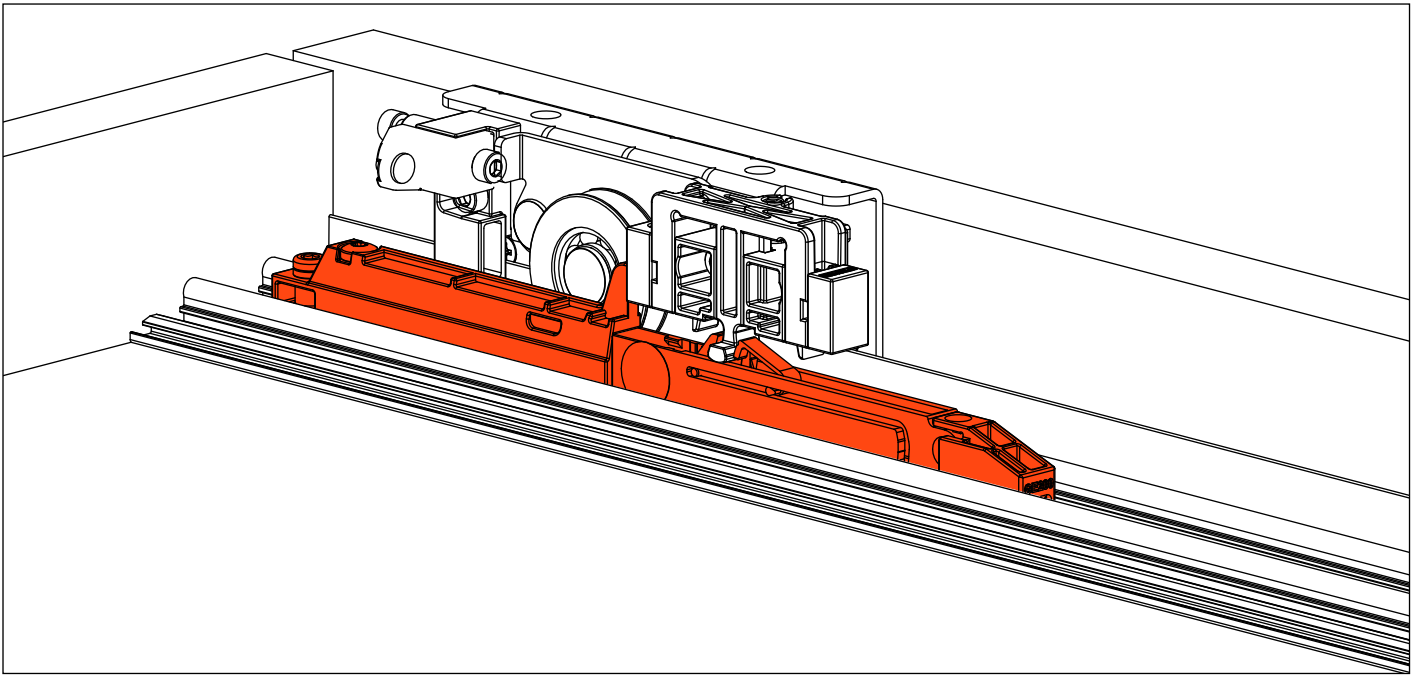

Stops that are extremely easy to fit and position.

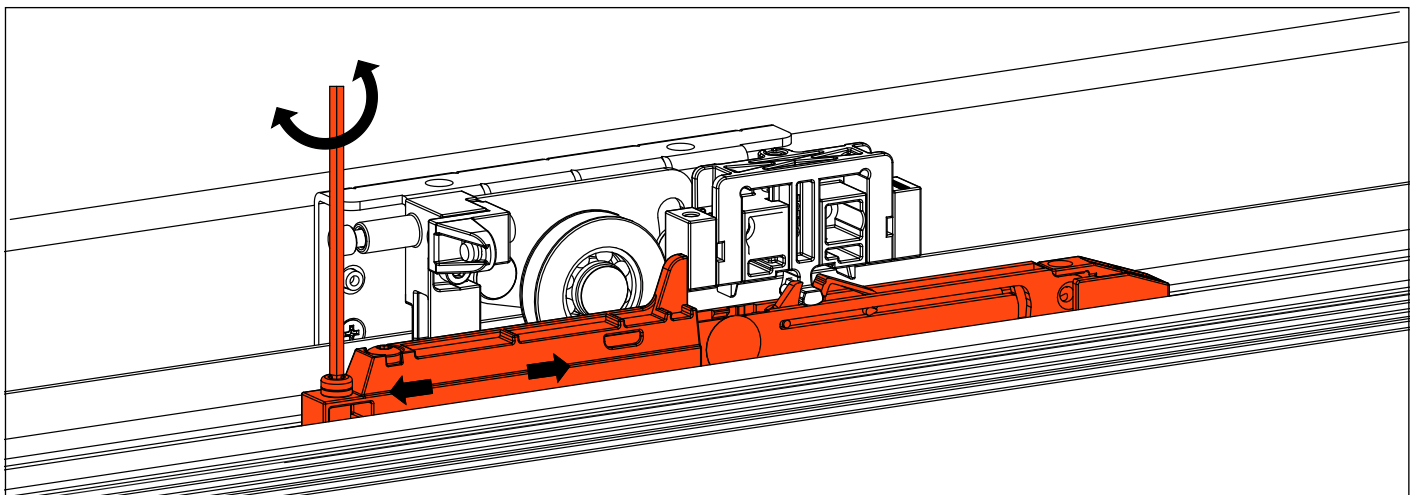

Automatic engage and release of the carriage and buffer.

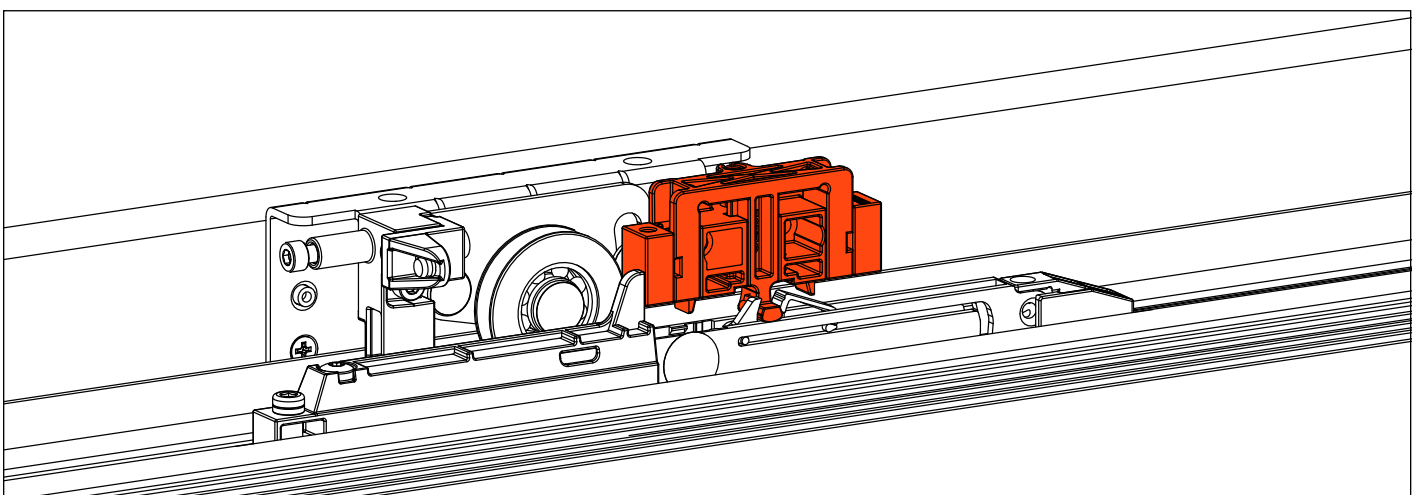

Glow+
Key features

Innovative magnetic damper, ensuring smooth and silent movement.

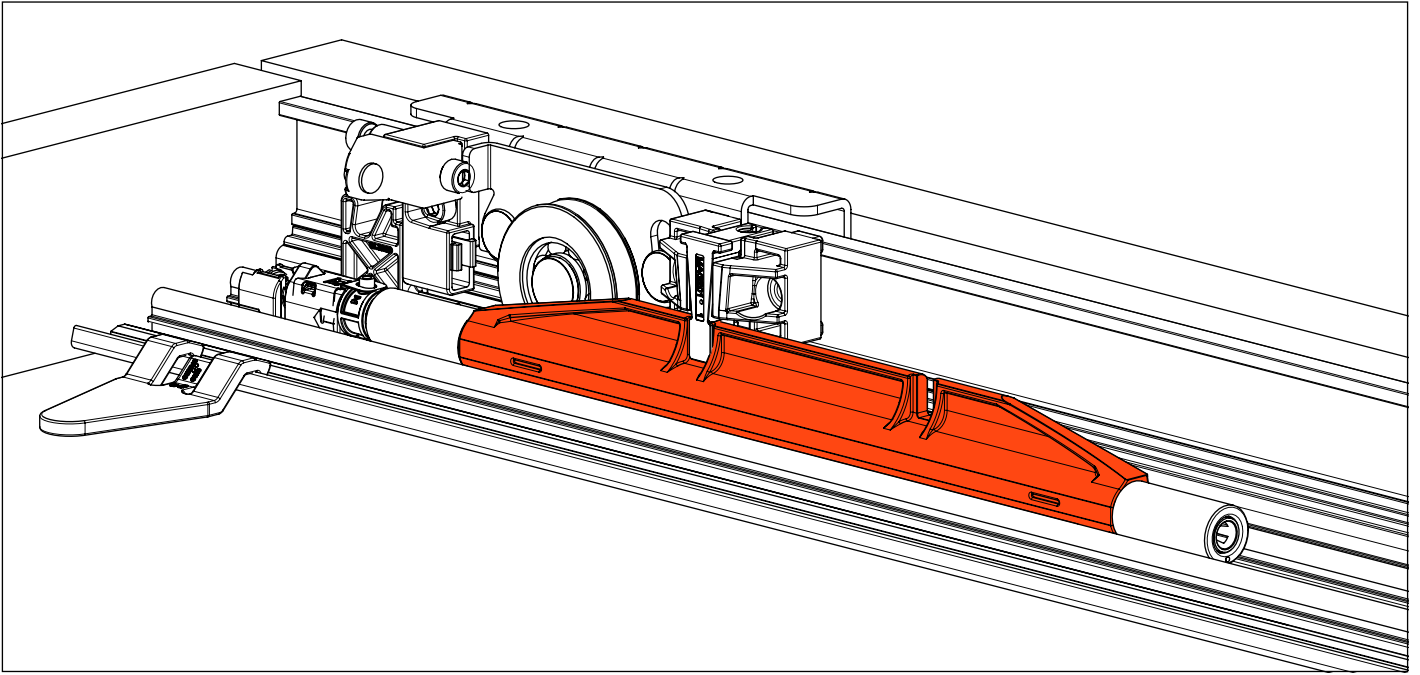

Stops that are extremely easy to fit and position.

Automatic engage and release of the carriage and buffer.

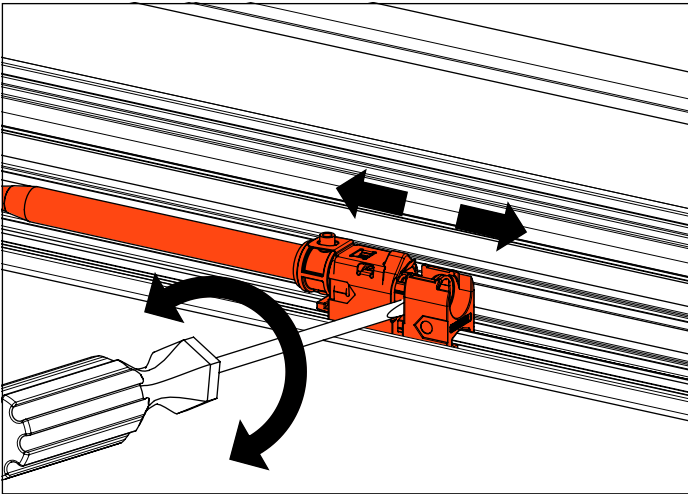

Front cover for the mechanism retained by magnets.

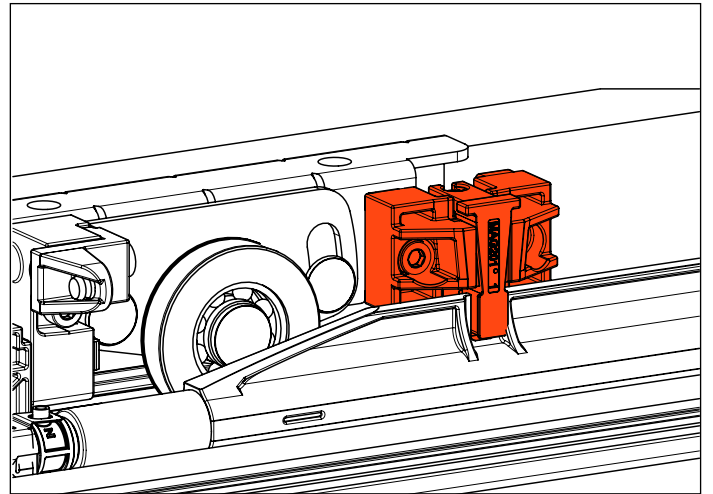

Guide tracks installed with press-fit clips.

