

Tilt Down

System for flap doors with downward opening



Technical information

System for downward-opening flap doors, side panel fixing, with external, recessed or flush assembly.

Decelerated closing and opening.

Version for doors with thickness from 18 to 22 mm:
machining depth on the door 15 mm.

Version for thicker doors with thickness from 22 to 30 mm:
machining depth on the door 20 mm.

90° opening.

"K" drilling on the door 11 mm.

External assembly with cover

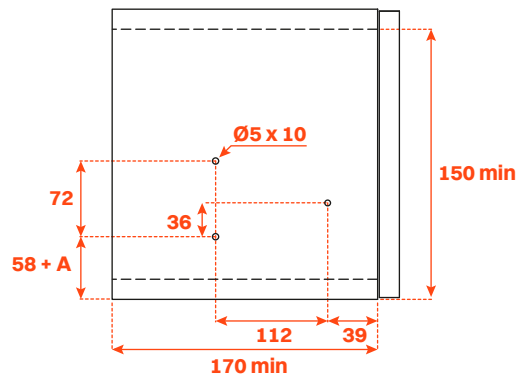

Recessed assembly in counter side panel

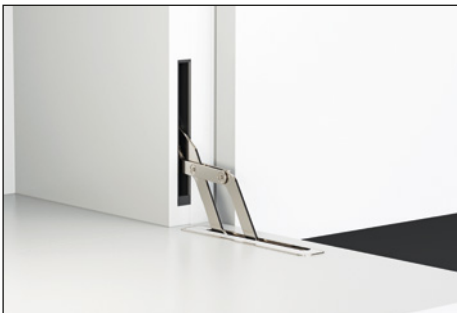

Counter side panel machining

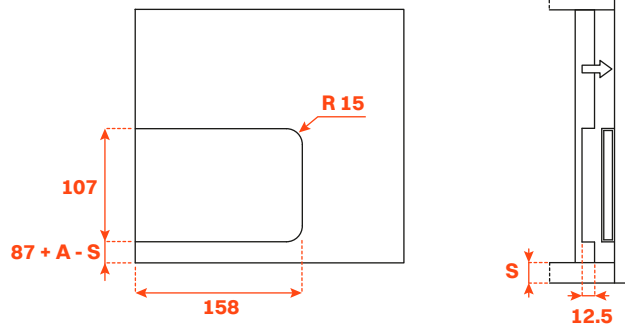

Required space for door opening

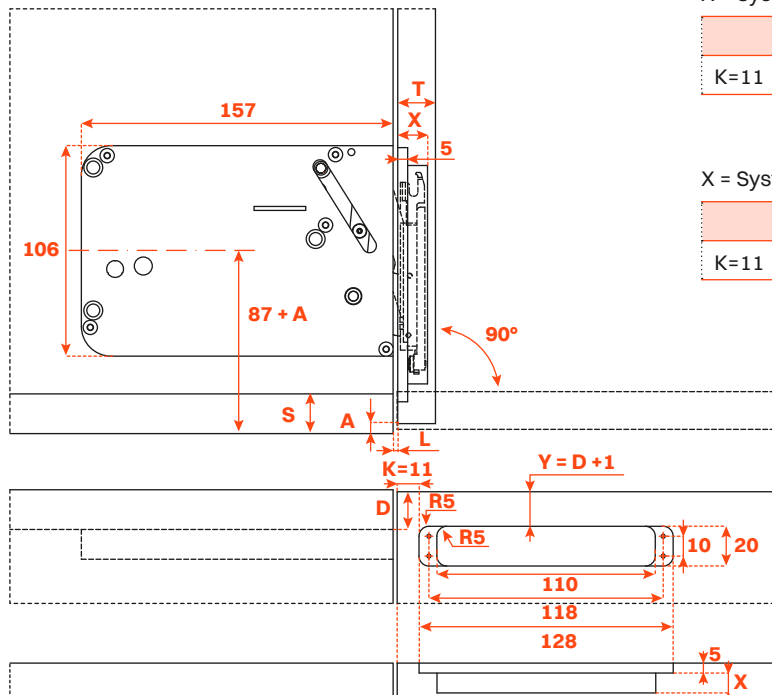

X = System for doors from 18 mm to 22 mm (X = 10 mm)

T=	18	19	20	21	22
K=11 A=	0.0	0.0	0.0	1.0	2.0

X = System for doors from 22 mm to 30 mm (X = 15 mm)

T=	22	23	24	26	28	30
K=11 A=	0.0	0.0	0.0	0.0	2	4

Flush recessed assembly with cover

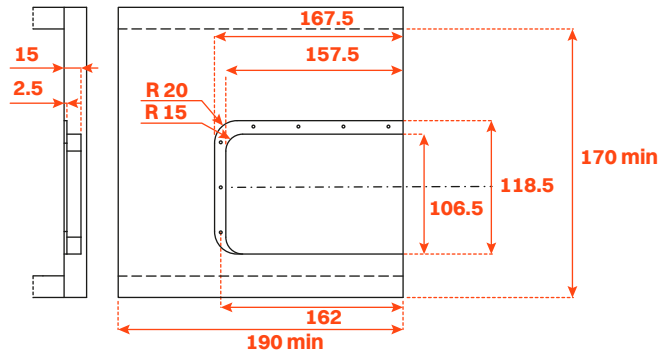
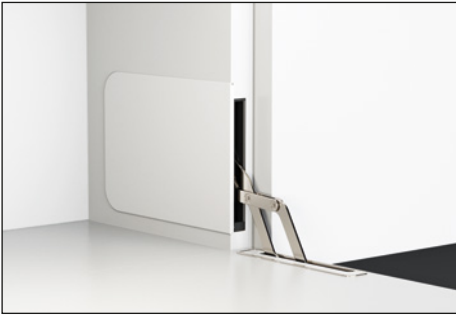

Required space for door opening

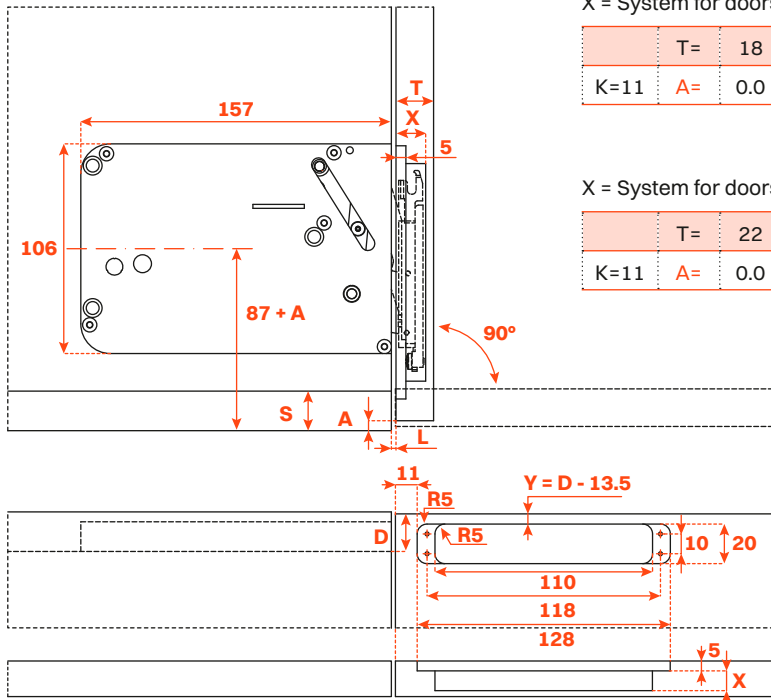

X = System for doors from 18 mm to 22 mm (X = 10 mm)

T=	18	19	20	21	22	
K=11	A=	0.0	0.0	0.0	1.0	2.0

X = System for doors from 22 mm to 30 mm (X = 15 mm)

T=	22	23	24	26	28	30	
K=11	A=	0.0	0.0	0.0	0.0	2	4