

Tilt Up

System for flap doors with upward opening

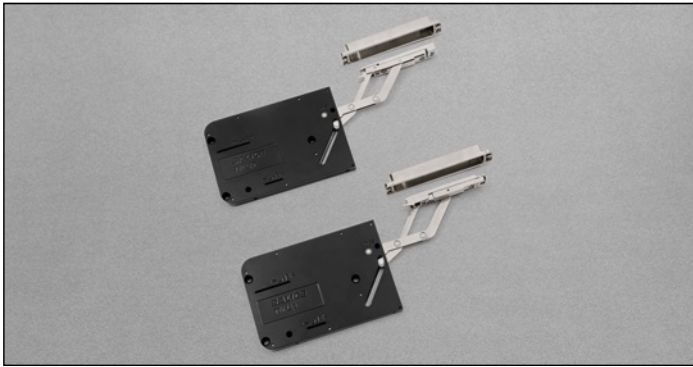

Technical information

System for upward-opening flap doors, side panel fixing, with external, recessed or flush assembly.

Decelerated closing.

Version for doors with thickness from 18 to 30 mm:
machining depth on the door 15 mm.

80° opening with opening limiter.

95° opening with opening limiter disengaged.

"K" drilling on the door 11 mm.

External assembly with cover

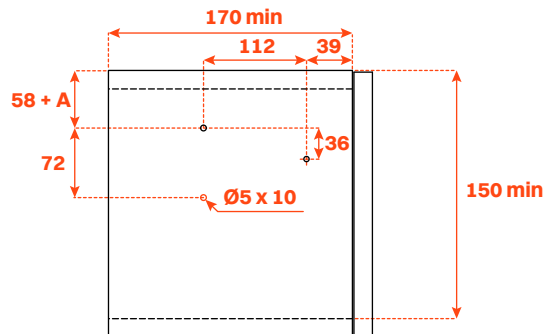

Recessed assembly in counter side panel



Counter side panel machining

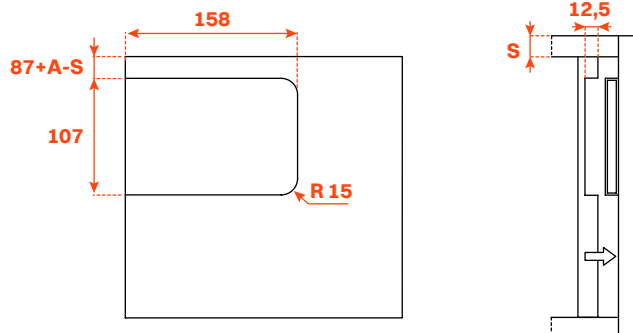

Required space for door opening

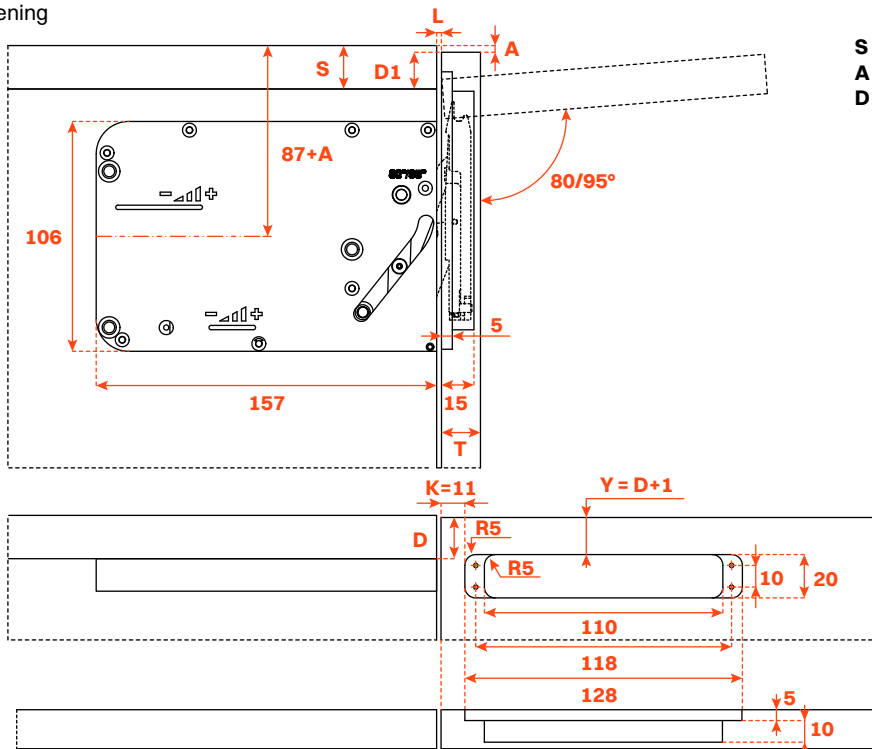

S max = 30
A min = 1
D1 = S - A

Flush recessed assembly with cover

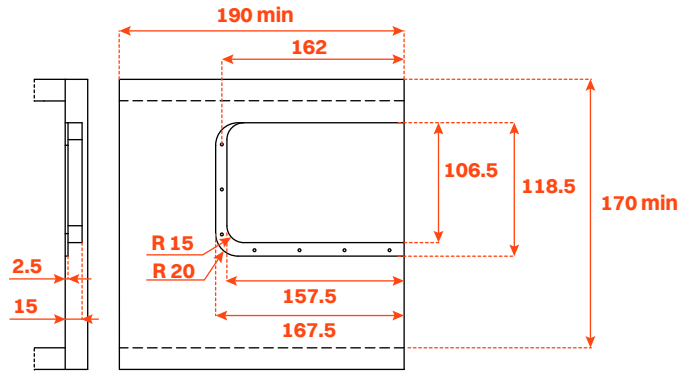

Required space for door opening

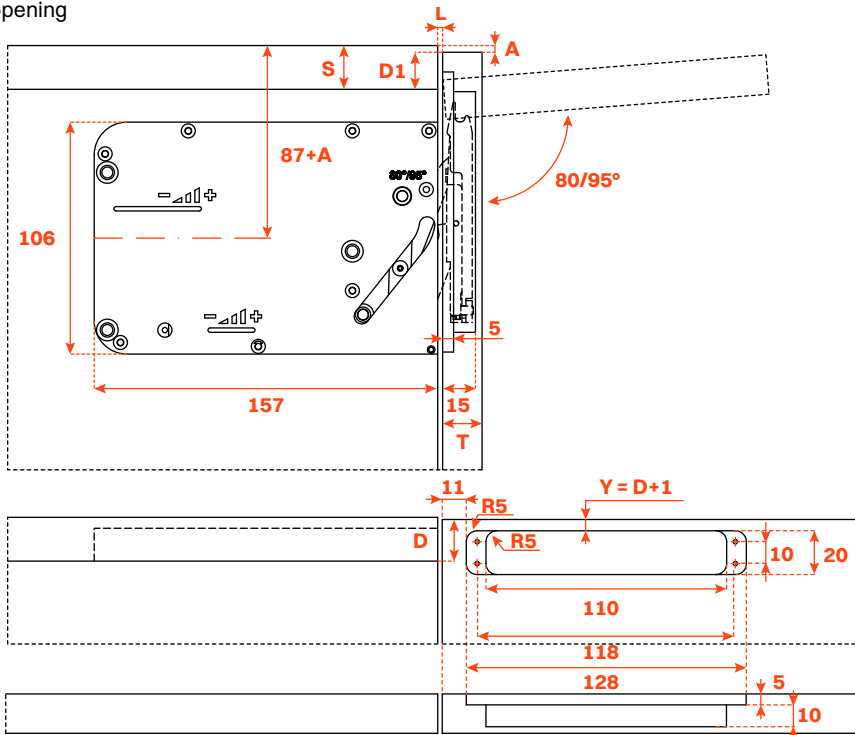

Construction with 2 overlapped systems.

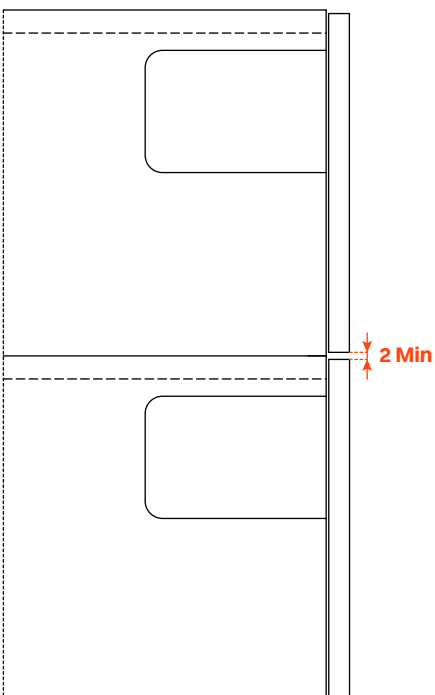

Construction with protruding top.

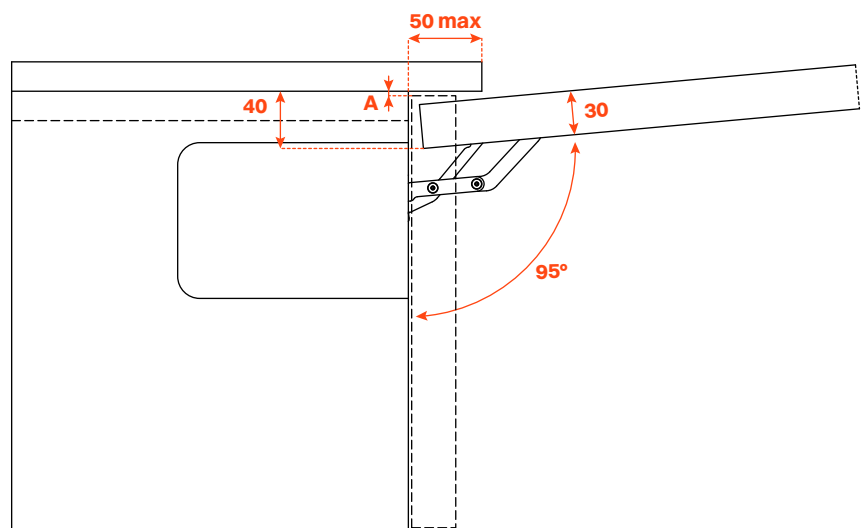

With $A = 1$ mm, the maximum top projection is 50 mm and the maximum door thickness is 30 mm.