

Tilt Up

Sistema per ante a ribalta con apertura verso l'alto

Montaggio meccanismo

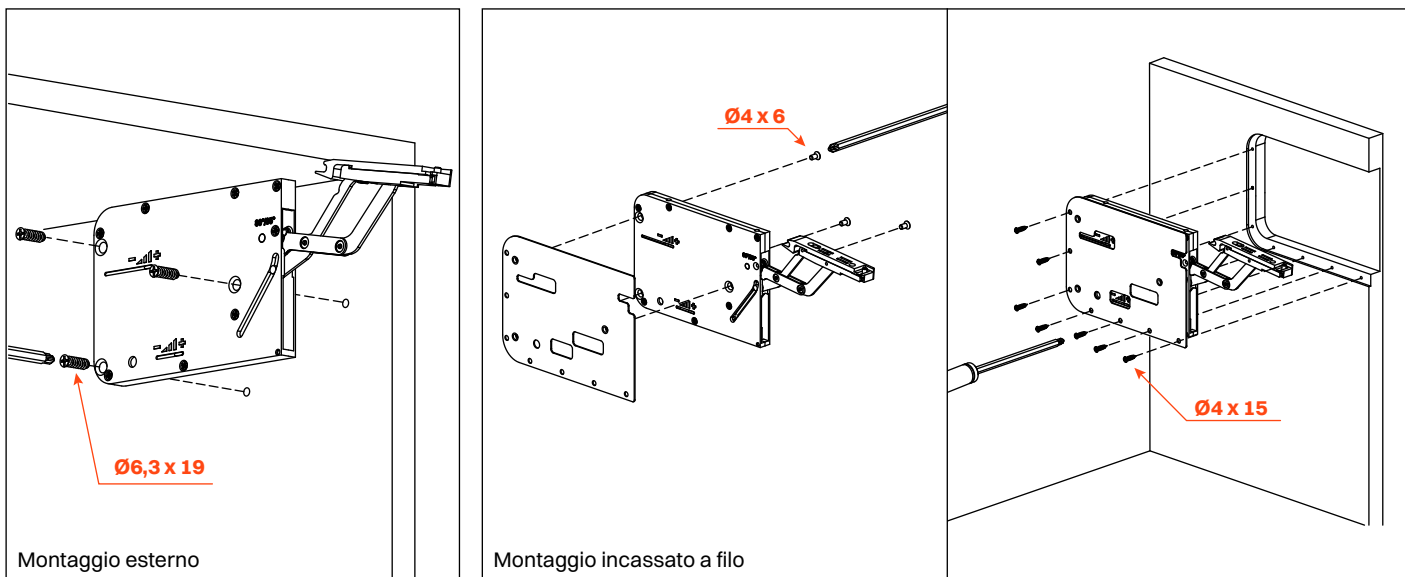

Fissaggio attacco anta

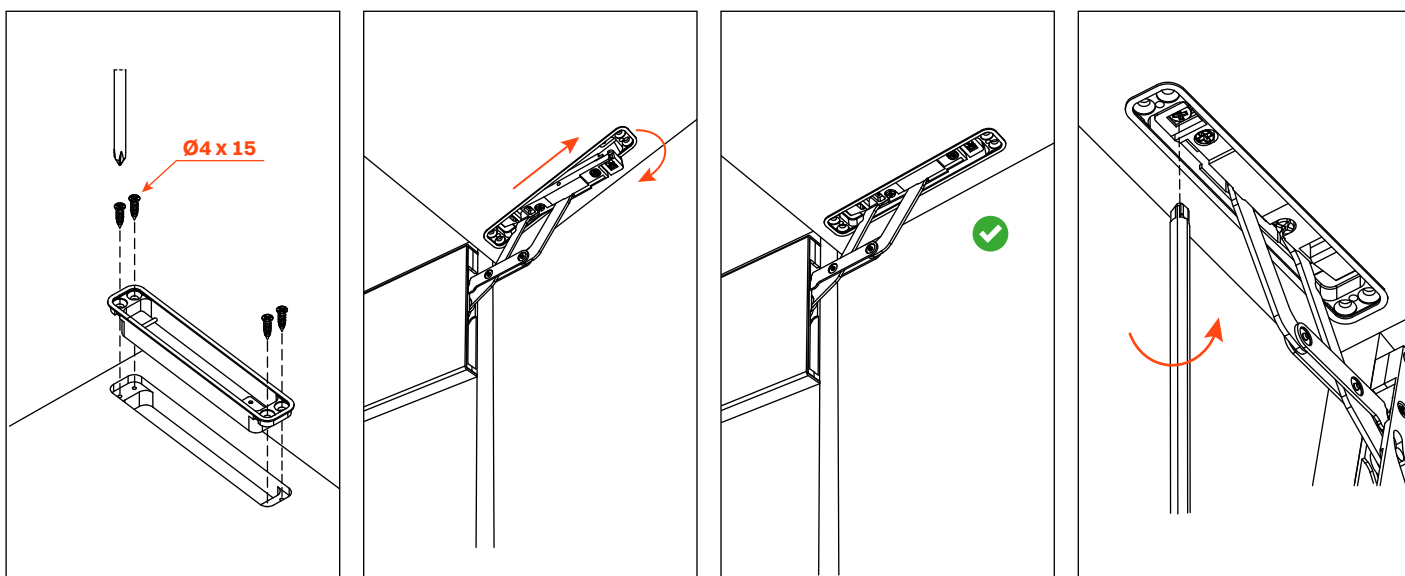

Rimozione limitatore di apertura a 80°

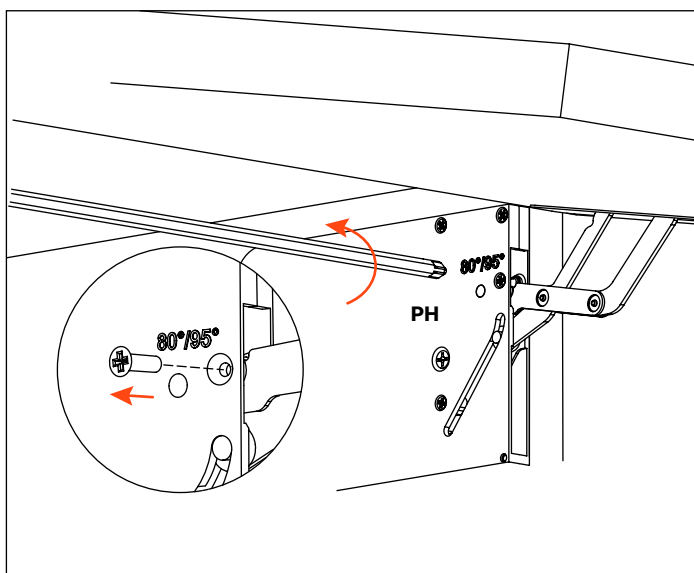

Fissaggio carter di copertura attacco anta

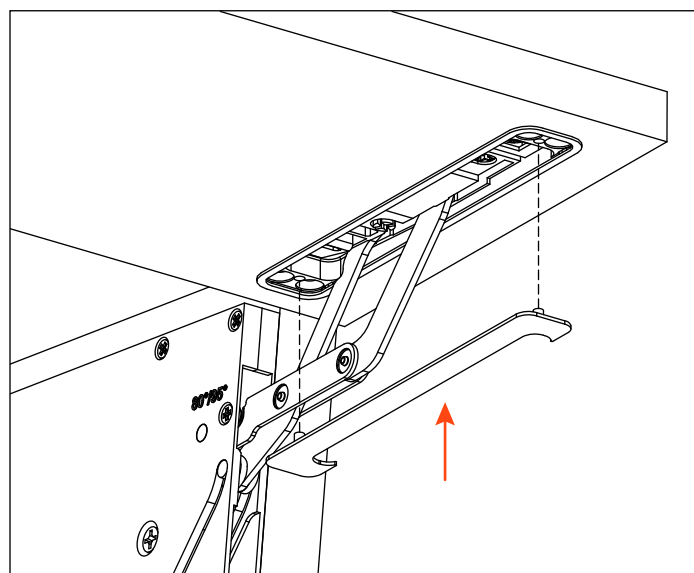

Montaggio carter di copertura esterno

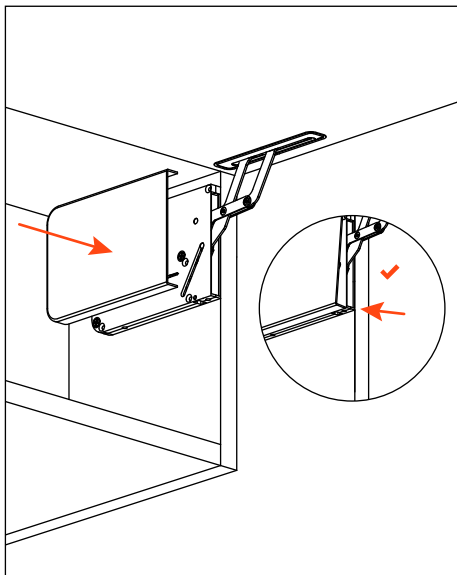

Montaggio controspalla

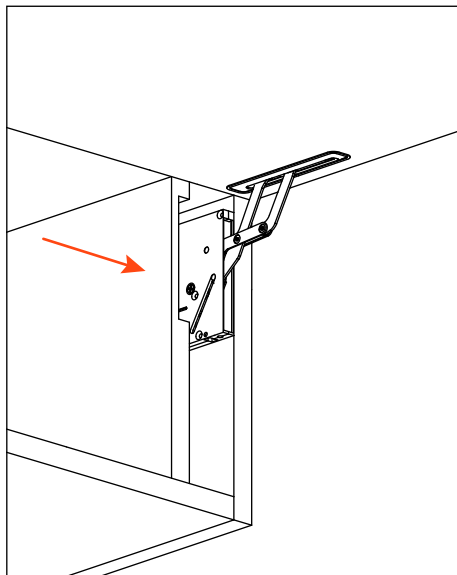

Montaggio carter di copertura a filo

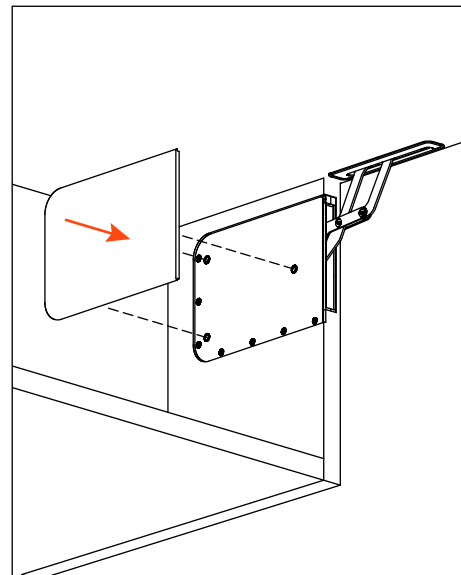

Regolazione molla

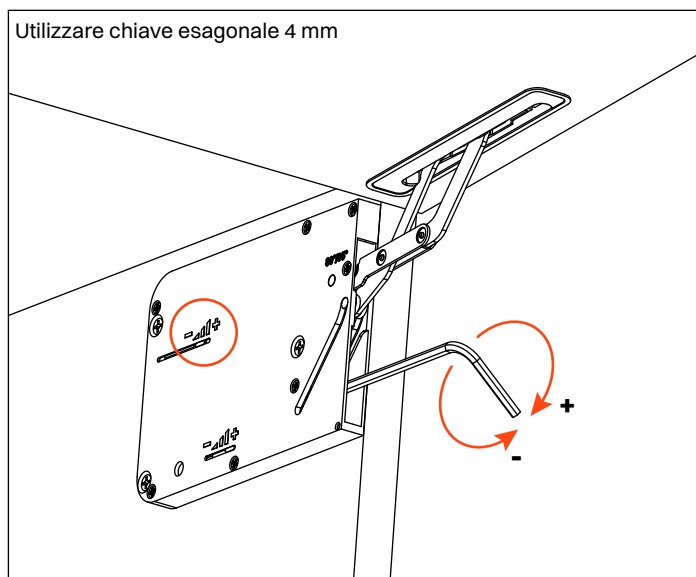

Regolazione forza decelerante

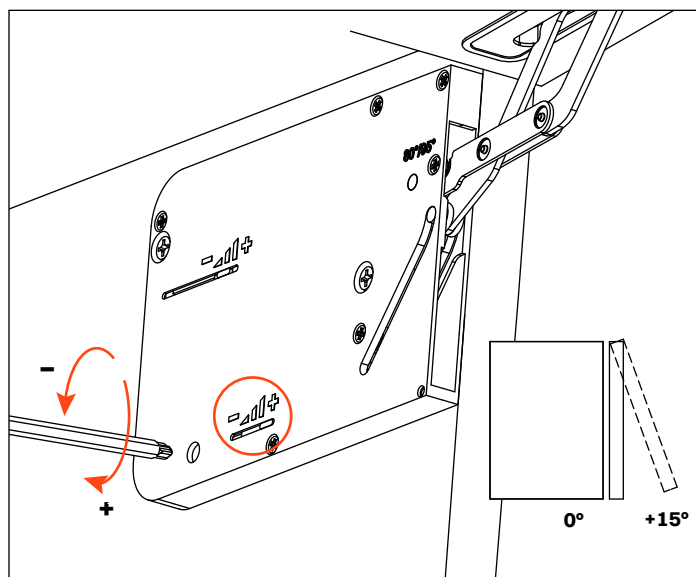

Regolazione verticale

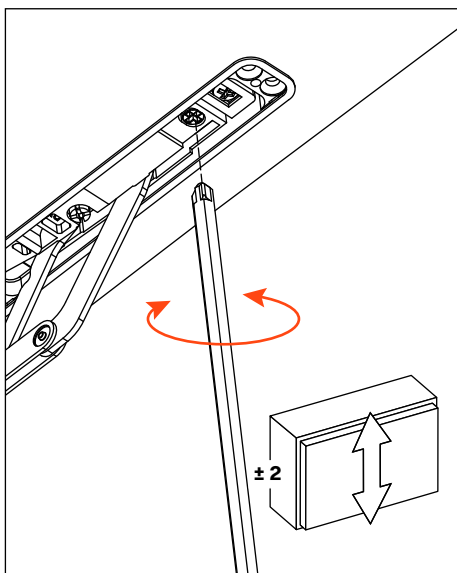

Regolazione laterale

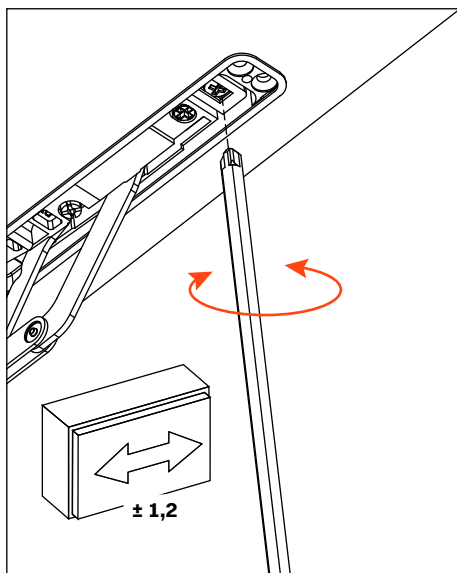

Regolazione frontale

