



Mover Flat

Assembly instructions
and order form



Mover Flat



Product overview

Vertical downward sliding system for single door.

Tech features:

- width 900 mm (35 - 7/16")
1200 mm (47 - 7/32")
1800 mm (71 - 1/16")
2400 mm (94 - 1/2")
- height from 480 mm (18 - 7/8")
to 628 mm (24 - 3/4")

Thickness of the cabinet side:

- 19 mm (3/4")

Adjustment:

- height adjustment ± 3 mm (1/8")

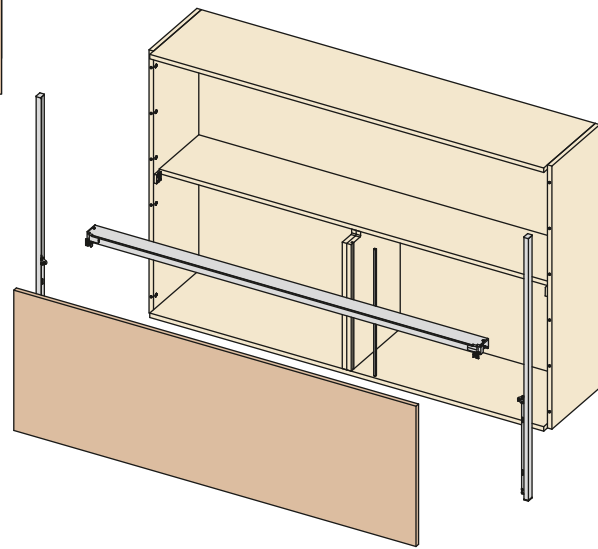
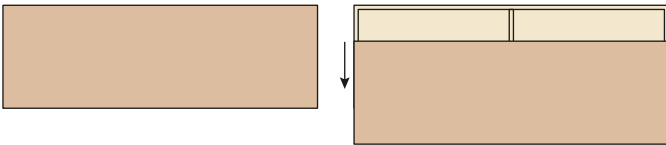

Components of the system

Horizontal supporting profile.

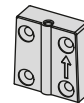
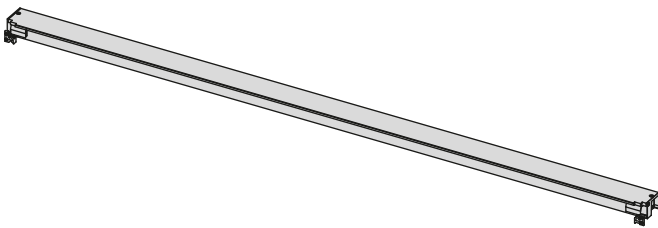

Fixing supports for the profile.



Pair of runners to cut to length.



Tie-rods and cams to fix the runners.

Sliding profile for central panel.

Required only for versions with doors of 1800mm and 2400mm width.



Bumpers.
Hooks to mount the door onto the system.

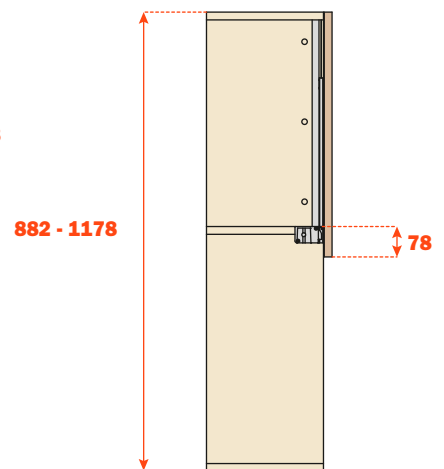
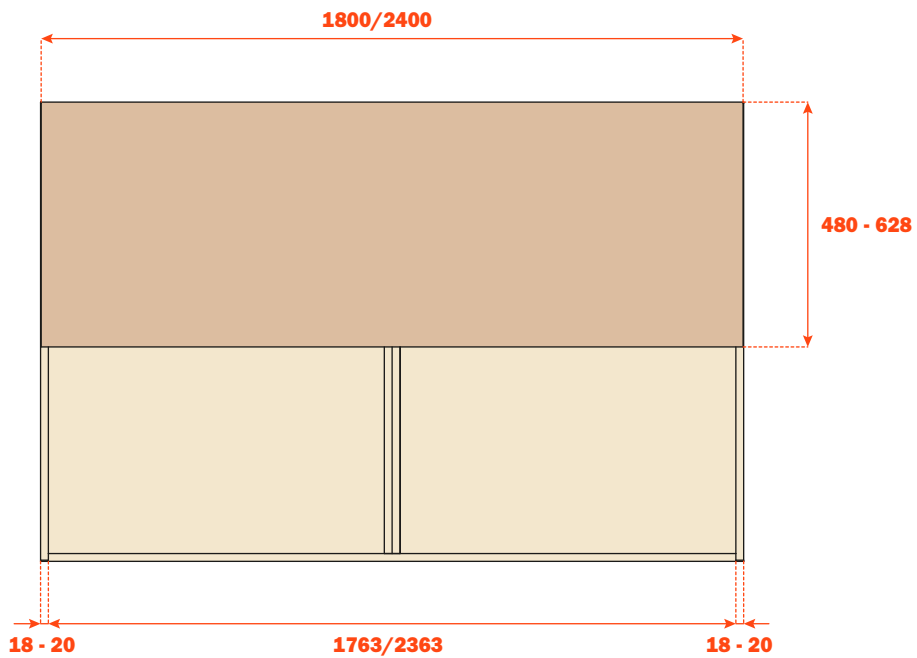
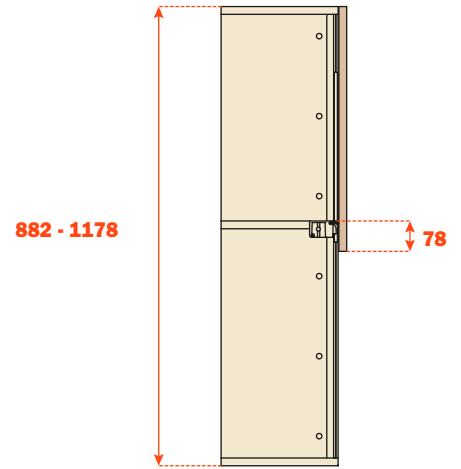
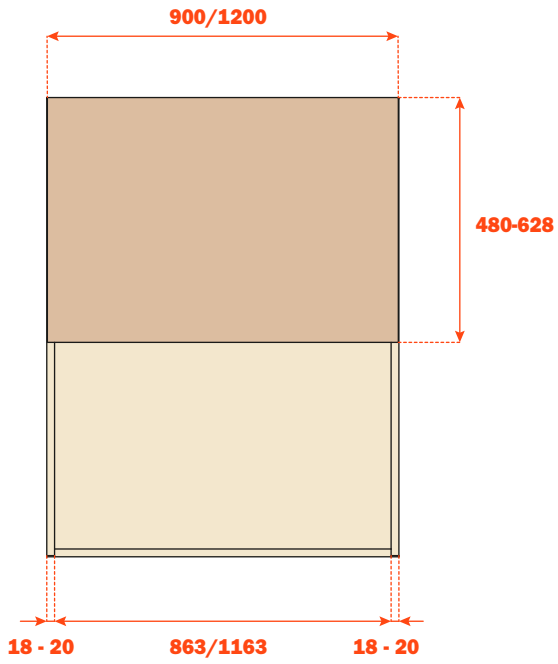

Mover Flat - Cabinet drilling

Side panel drilling required for the system

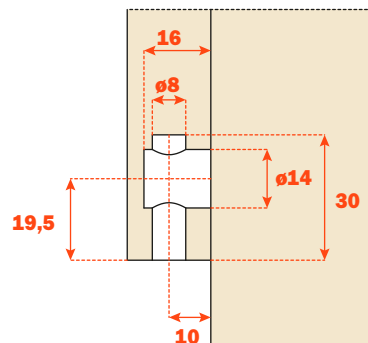
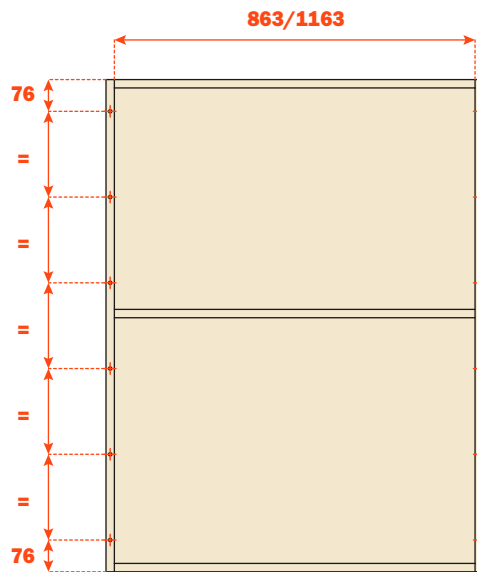
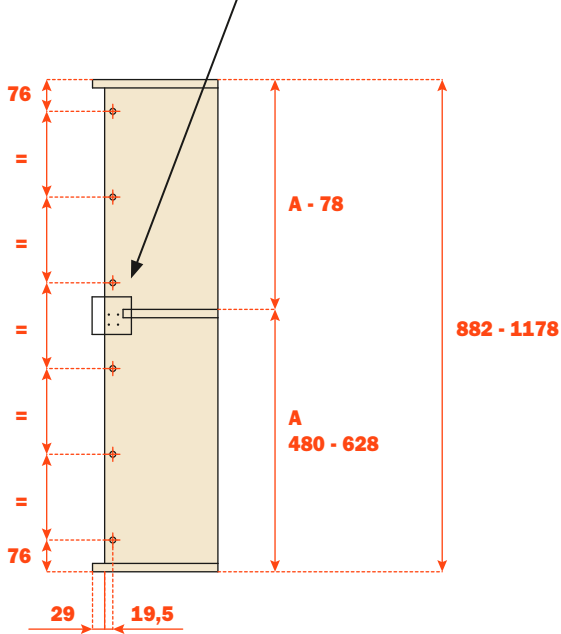
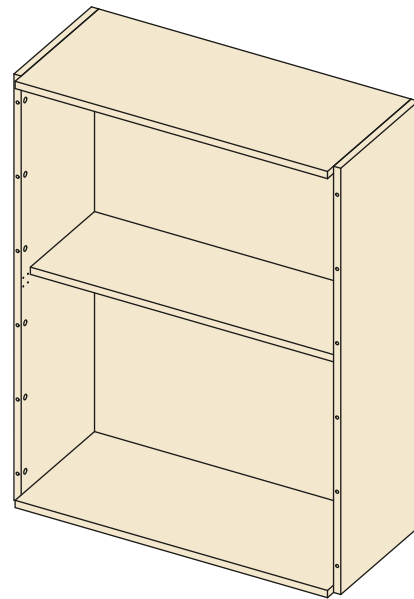
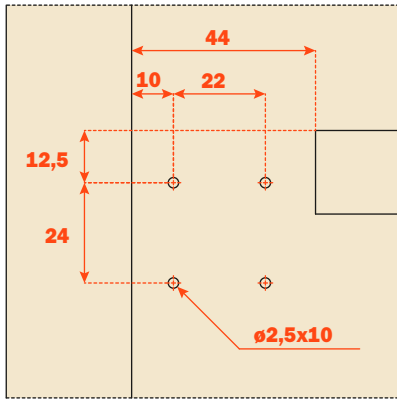

Side panel drilling to fix the runners - 19/20 mm wall thickness

Door drilling

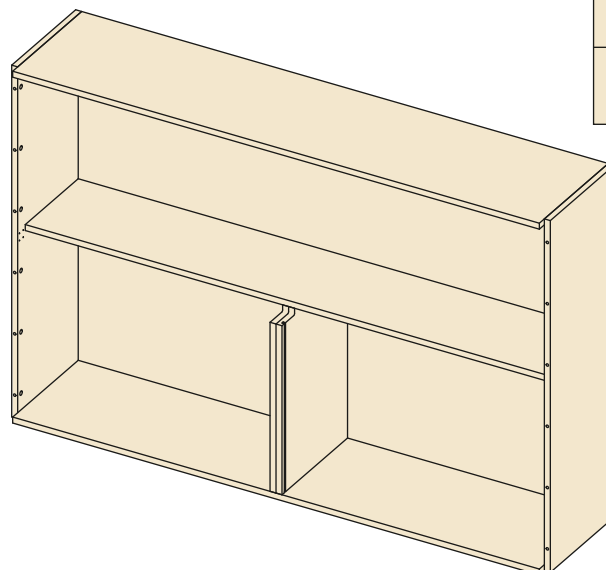
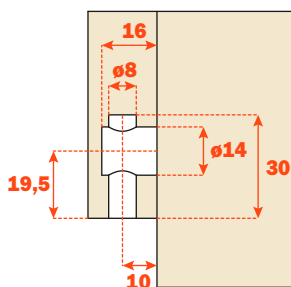
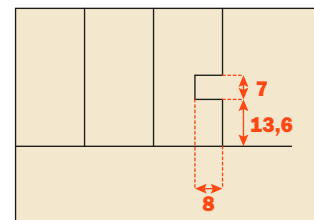
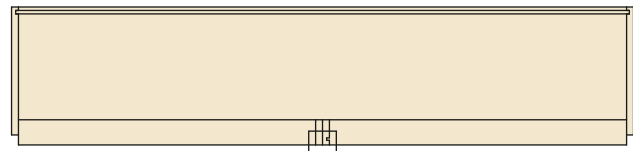
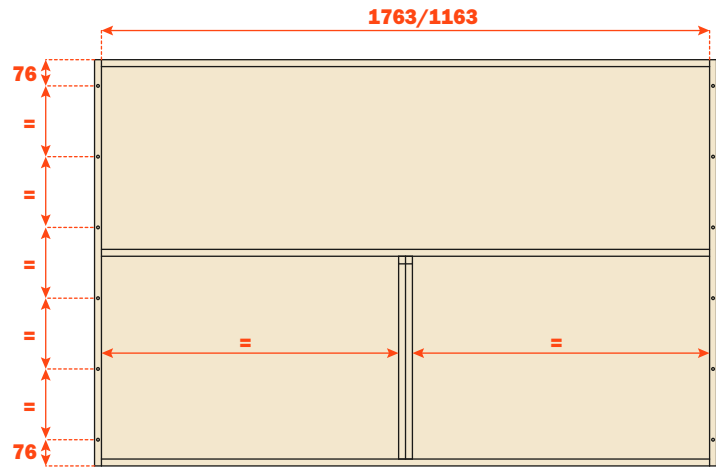
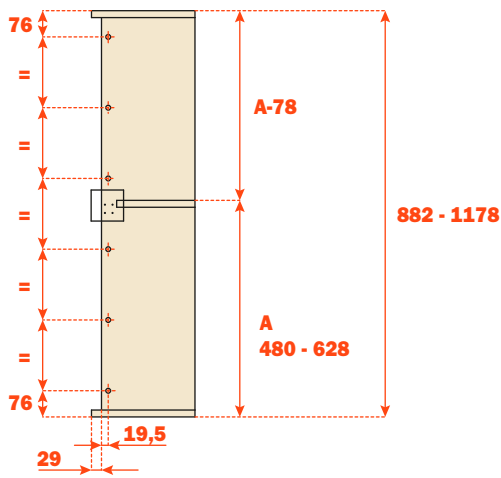
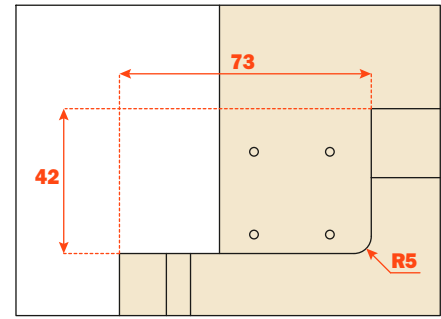
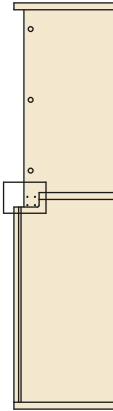
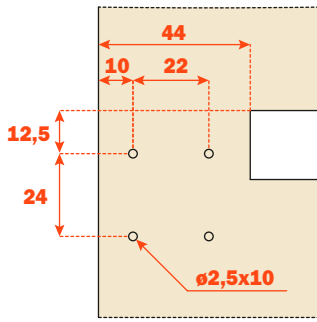

Side panel drilling to fix the runners - 19/20 mm wall thickness

Mover Flat - Door drilling

Drilling patterns with sides 19/20 mm

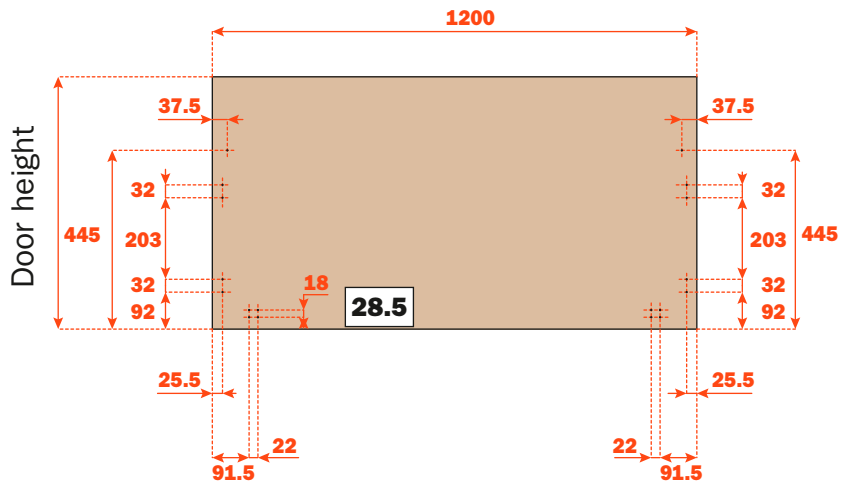
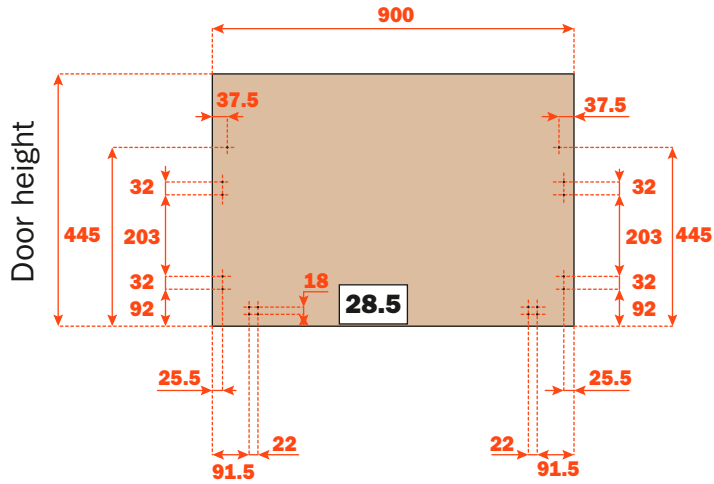

Drilling patterns with sides 19/20 mm

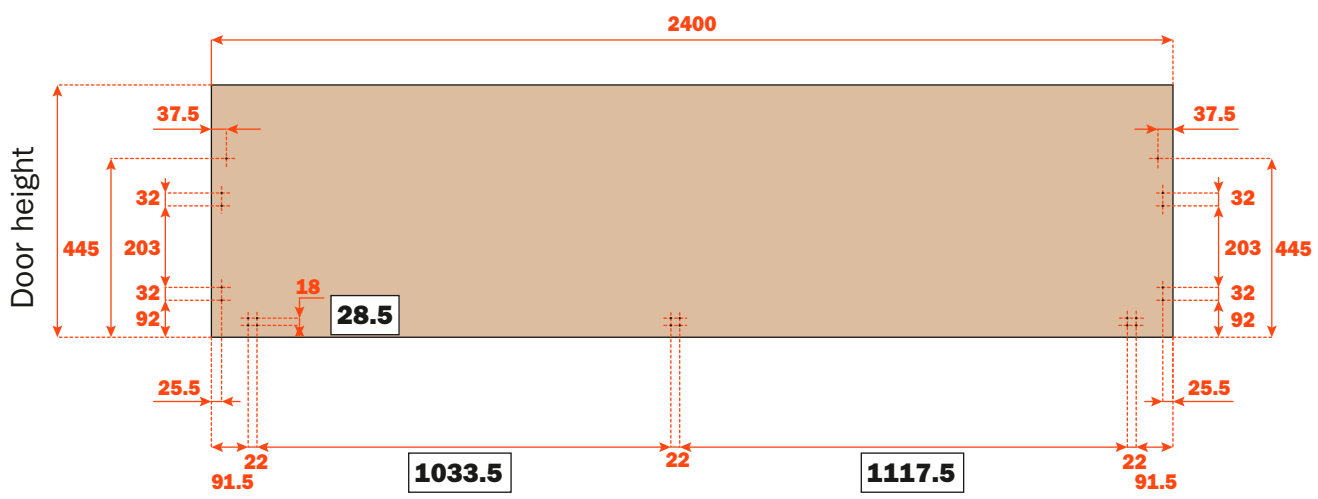
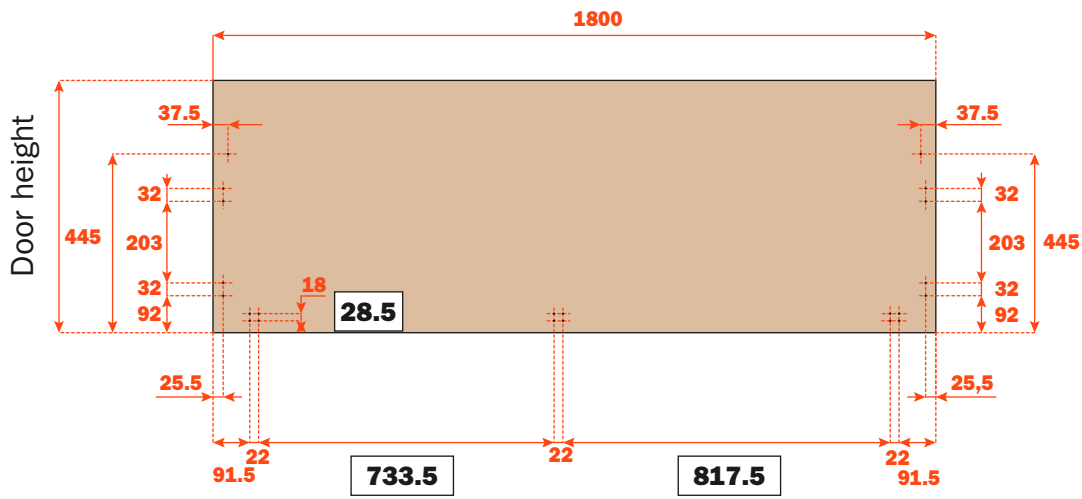

Mover Flat - Part number composition

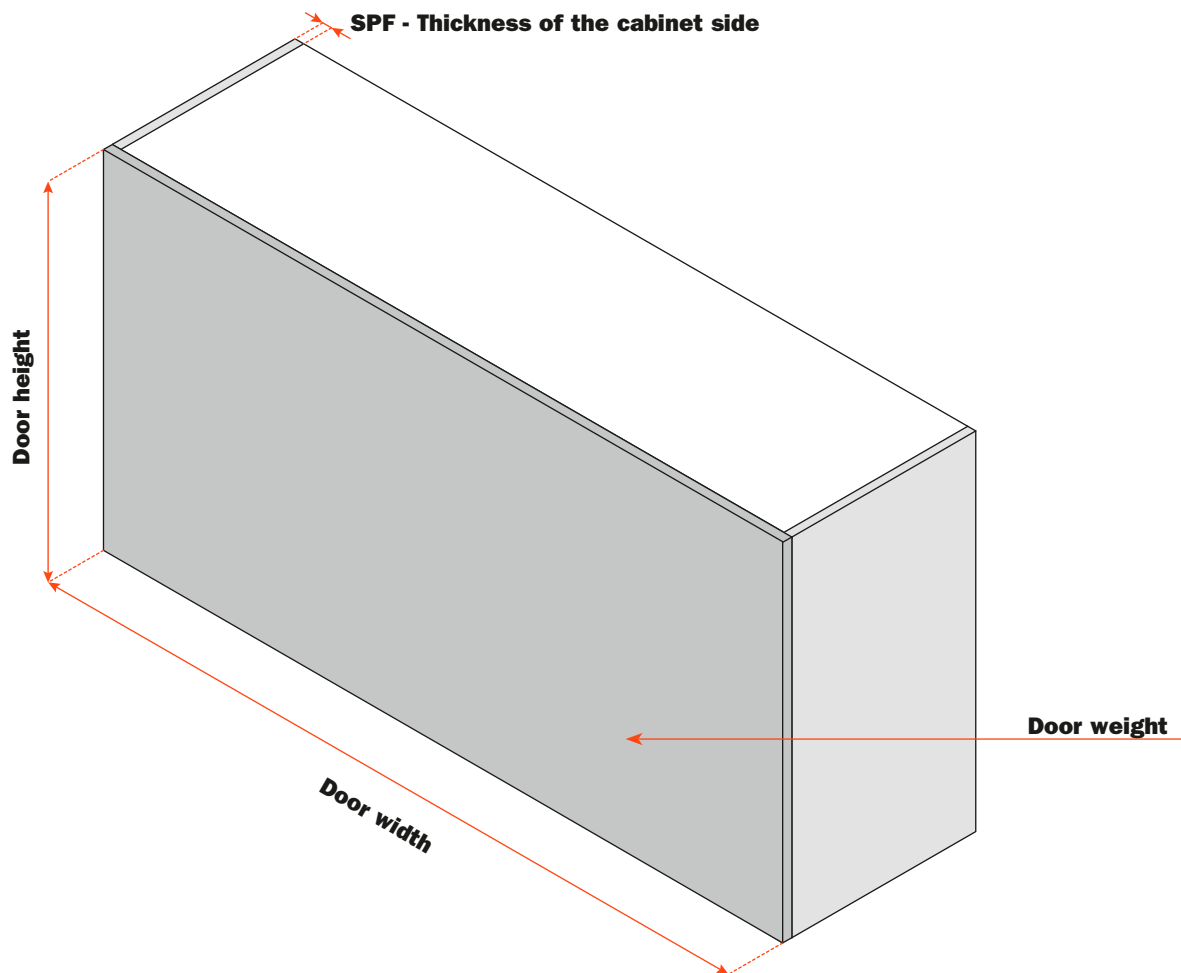

Part number	Thickness of the cabinet side mm	Door width mm	Door weight Kg	Door weight Lb
YE28MFL090020A1	19/20	900	6 - 8	13,2 - 17,6
YE28MFL120020A1	19/20	1200	10 - 12	22 - 26,4
YE28MFL180020A1	19/20	1800	15 - 17	33 - 37,4
YE28MFL240020A1	19/20	2400	21 - 23	46,2 - 50