

## Slider L100



**Slider L100** is the coplanar system for cabinets with doors weighing up to 100 kg. Based on L70, it pushes the limits further, delivering the smoothness and lightness of touch typical of Salice even with particularly heavy doors.

Available in two- or three-door variants, it can be specified with a customisable front cover. Its features of reliability, modularity and capacity make **L100** ideal for wardrobes in bedrooms and for all large cabinets in general.



## Slider L100



### Technical information

Coplanar two-door cushioned sliding system.  
Capacity 100 kg per door.

Individual door properties:

- max. weight per door 100 kg (evenly distributed)
- width: - min. 800 mm  
- max. 2000 mm
- height: - max. 3000 mm
- thickness: - min. 18 mm  
- max. with handle 45 mm
- material: a) wood or derived material  
b) glass with metal frame

Door adjustment:

- vertical adjustment  $\pm 5$  mm
- horizontal adjustment  $\pm 3.5$  mm
- front adjustment: - upper  $\pm 4$  mm  
- lower  $\pm 3$  mm

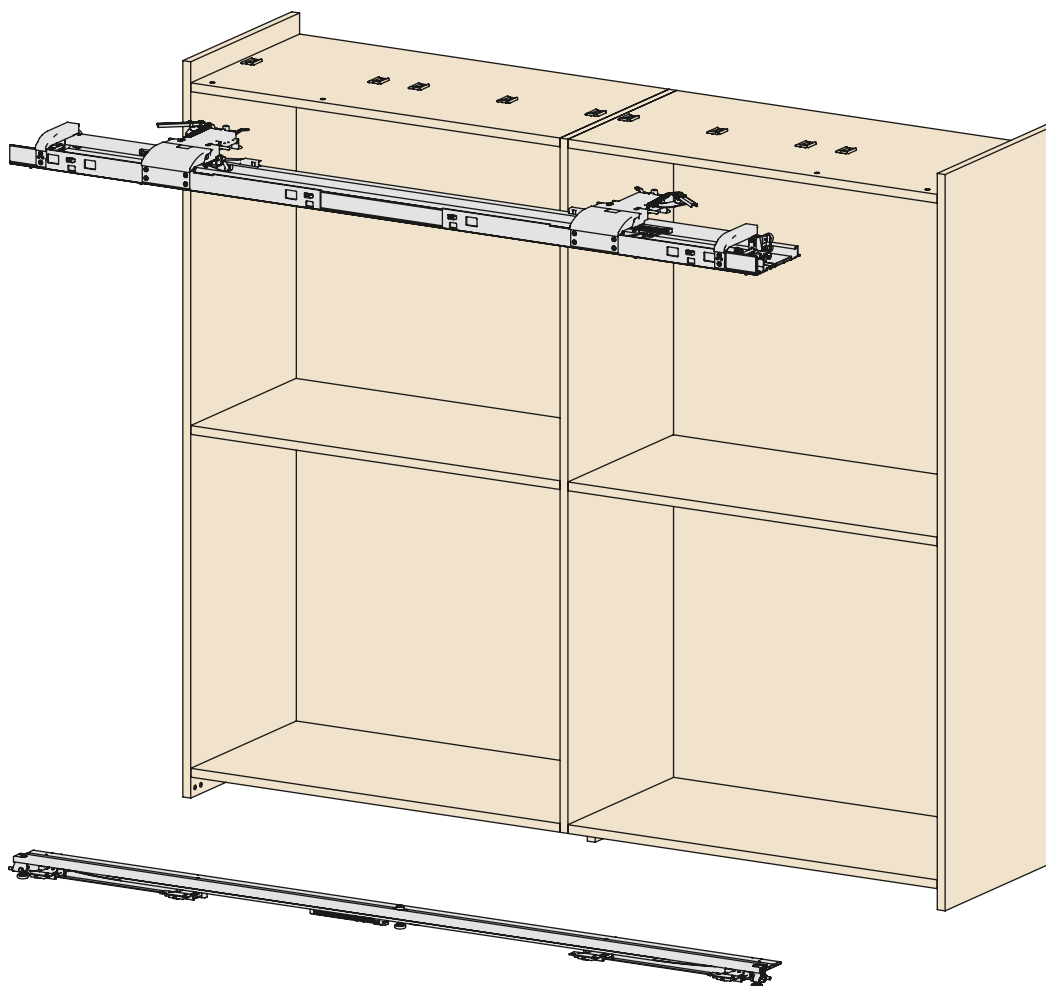

## Key feature

- Soft closing with linear damper.
- Aluminium and PVC guide tracks for smooth, silent movement.
- Curves designed to fit the unit size.
- Pre-assembled mechanism for fast, safe assembly.
- Smooth cushioned opening and closing.
- Extremely tough and long-lasting, subjected to 100,000 cycles of the stress test.

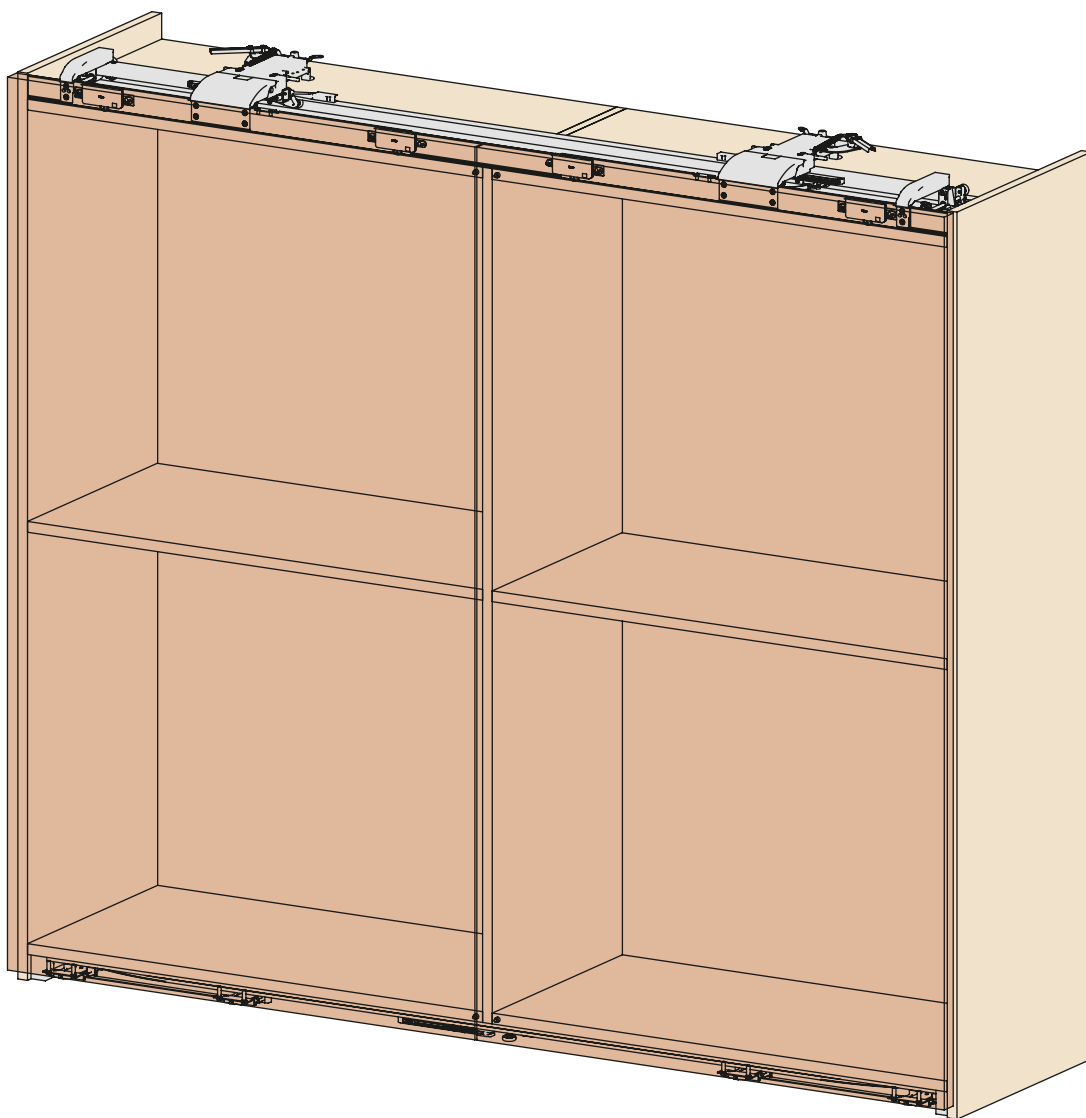

**Available versions**

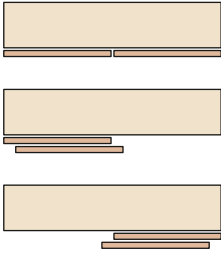
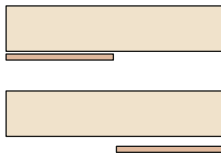
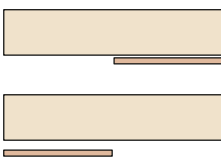
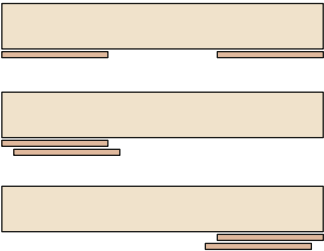
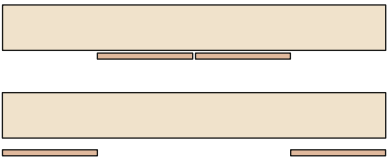
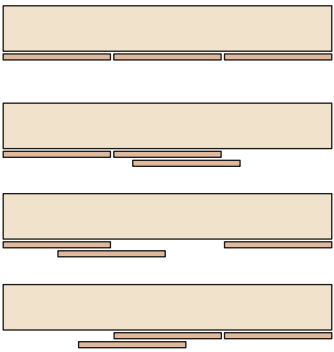
<p><b>Standard</b></p>		<p><b>Slider L70</b> <b>Slider L100</b></p>	
<p><b>One</b></p>		<p><b>Slider L70</b></p>	
<p><b>One</b></p>		<p><b>Slider L70</b></p>	
<p><b>Step</b></p>		<p><b>Slider L70</b> <b>Slider L100</b></p>	
<p><b>Reverso</b></p>		<p><b>Slider L70</b></p>	
<p><b>Three doors</b></p>		<p><b>Slider L70</b></p>	