



Slider L70

Assembly instructions
and order form



Slider L70



Coplanar Sliding Door System for tall double door cabinets with soft door opening and soft closing feature with magnetic technology -heavy duty.

Product overview

- For wood or glass with aluminum-framed doors

Tech features:

- Max. weight capacity per door: 70 kg (154 lbs)
- Width of the door: min. 800 mm (31 - 1/2")
max. 2000 mm (78 - 3/4")
- Max. height of the door: 3000 mm (118 - 1/8")
- Height of the door from floor level: 33 mm (1 - 11/32")
- Min. thickness of the door: min. 19 mm (3/4")
- Max. thickness of the door with handle: 45 mm (1 - 3/4")
- Door height adjustment: ± 5 mm ($\pm 3/16$ ")
- Door side adjustment: ± 3.5 mm ($\pm 1/8$ ")
- Door distance from the floor level 33 mm (1 - 11/32")
- Compatible with our Clipper-aluminum door system
- Available for cabinets with dimensions up to 200 mm (7 - 7/8") longer than the mechanism
- Front levelling feet

- Applications with 3 doors possible only upon request as a custom order

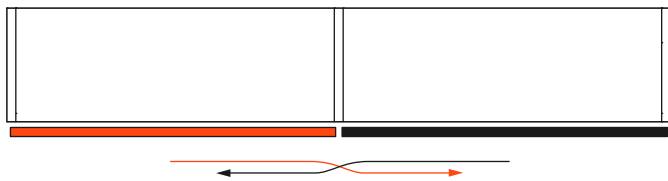

System components



Position the adjuster blocks on the doors

Upper sliding mechanism fixed to the top of the cabinet

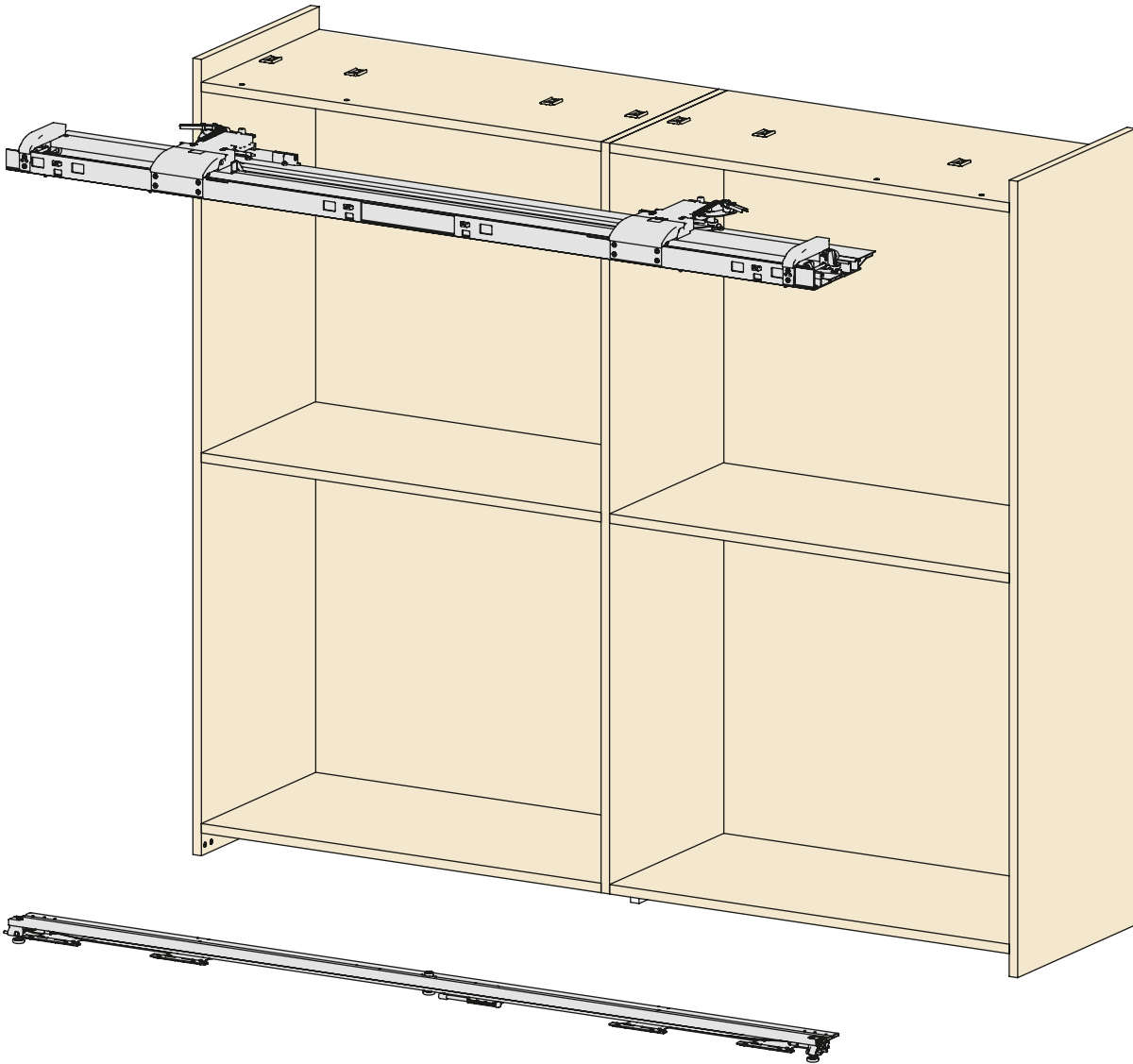

Lower sliding mechanism fixed under the cabinet bottom

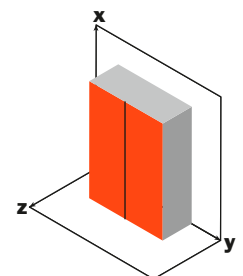

Slider L70

CODE REFERENCES

- LI** Internal cabinet width
- TL** Door width
- LHI** Internal cabinet height
- SPI** Support panel thickness
- D** Door overlay on side panel
- TH** Door height

- LHT** Total cabinet height
- S** Side panel thickness
- DBS** Space between track and side panel
- SPC** Top panel thickness
- SPB** Bottom panel thickness
- CP** Track length
- AA** Door protrusion

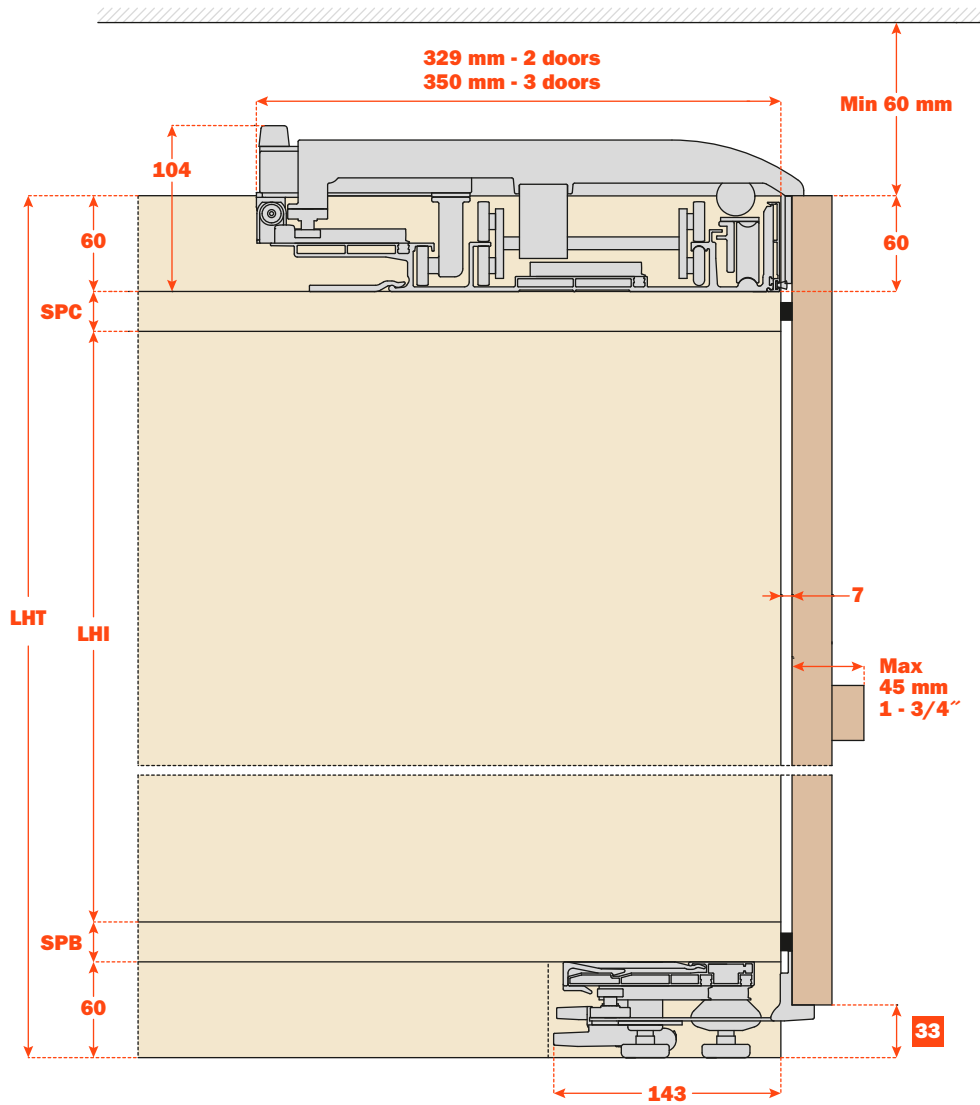

FLEXIBILITY OF INSTALLATION

The L70 2 doors stock size slider mechanisms can be installed on a carcass which may exceed the dimensions of the track itself by 200 mm (7 - 7/8"). The protrusion of the door in the open position is described with the formula: $DBS + D - (SPI/2) + 4.5$

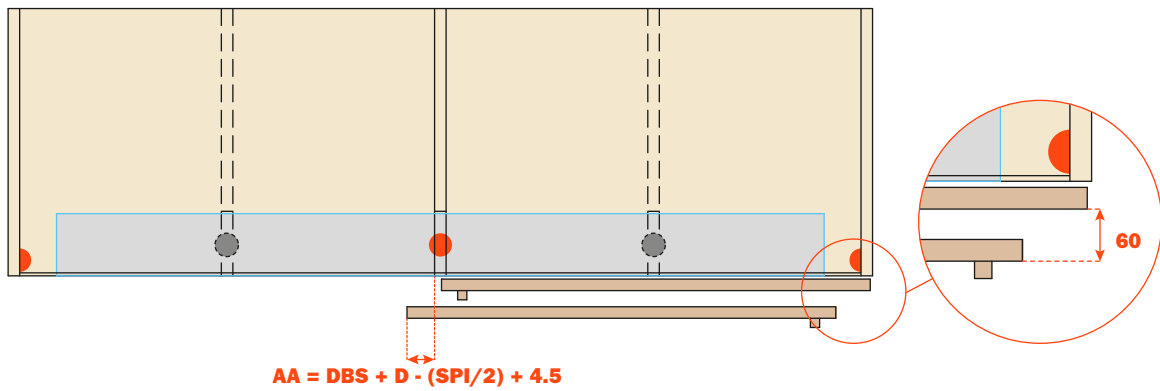
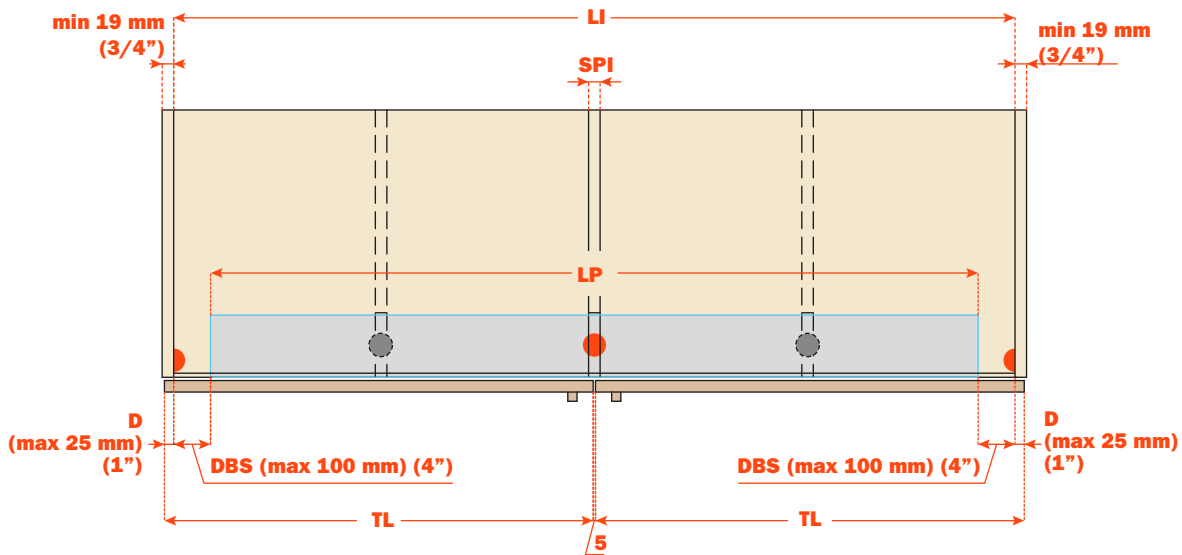

- Feet supplied with the track.
- Additional feet supplied on track (LP) over 2999 mm (118-1/8").

Slider L70 - Product codes and assembly specifications LEFT DOOR

Item #	Mechanism length (Lp) mm	Li	Overlay (D) mm	B	C	D	E	F	G	Packaging		Clipper frame	Max door Height mm
										Weight kg	Dimensions cm		
YE30FA01600NN	1599	1600-1800	1 - 25	169	303	154	472	341	-	26	175 x 46 x 19	YES	2700
YE30FA01800NN	1799	1800-2000	1 - 25	169	353	204	522	391	-	29.4	195 x 46 x 19	YES	2700
YE30FA02000NN	1999	2000-2200	1 - 25	169	403	254	572	441	-	32.8	215 x 46 x 19	YES	3000
YE30FA02200NN	2199	2200-2400	1 - 25	169	453	304	622	491	-	36.2	235 x 46 x 19	YES	3000
YE30FA02400NN	2399	2400-2600	1 - 25	169	503	354	672	541	-	39.6	255 x 46 x 19	YES	3000
YE30FA02600NN	2599	2600-2800	1 - 25	219	503	354	722	591	425	41.2	275 x 46 x 19	YES	3000
YE30FA02800NN	2799	2800-3000	1 - 25	269	503	354	772	641	475	43.4	295 x 46 x 19	YES	3000
YE30FA03000NN	2999	3000-3200	1 - 25	319	503	354	822	691	525	46.8	315 x 46 x 19	YES	3000
YE30FA03200NN	3199	3200-3400	1 - 25	369	503	354	872	741	575	49.2	335 x 46 x 19	NO	3000
YE30FA03400NN	3399	3400-3600	1 - 25	419	503	354	922	791	625	51.9	355 x 46 x 19	NO	3000
YE30FA03600NN	3599	3600-3800	1 - 25	469	503	354	972	841	675	54.6	375 x 46 x 19	NO	3000
YE30FA03800NN	3799	3800-4000	1 - 25	519	503	354	1022	891	725	57.3	395 x 46 x 19	NO	3000

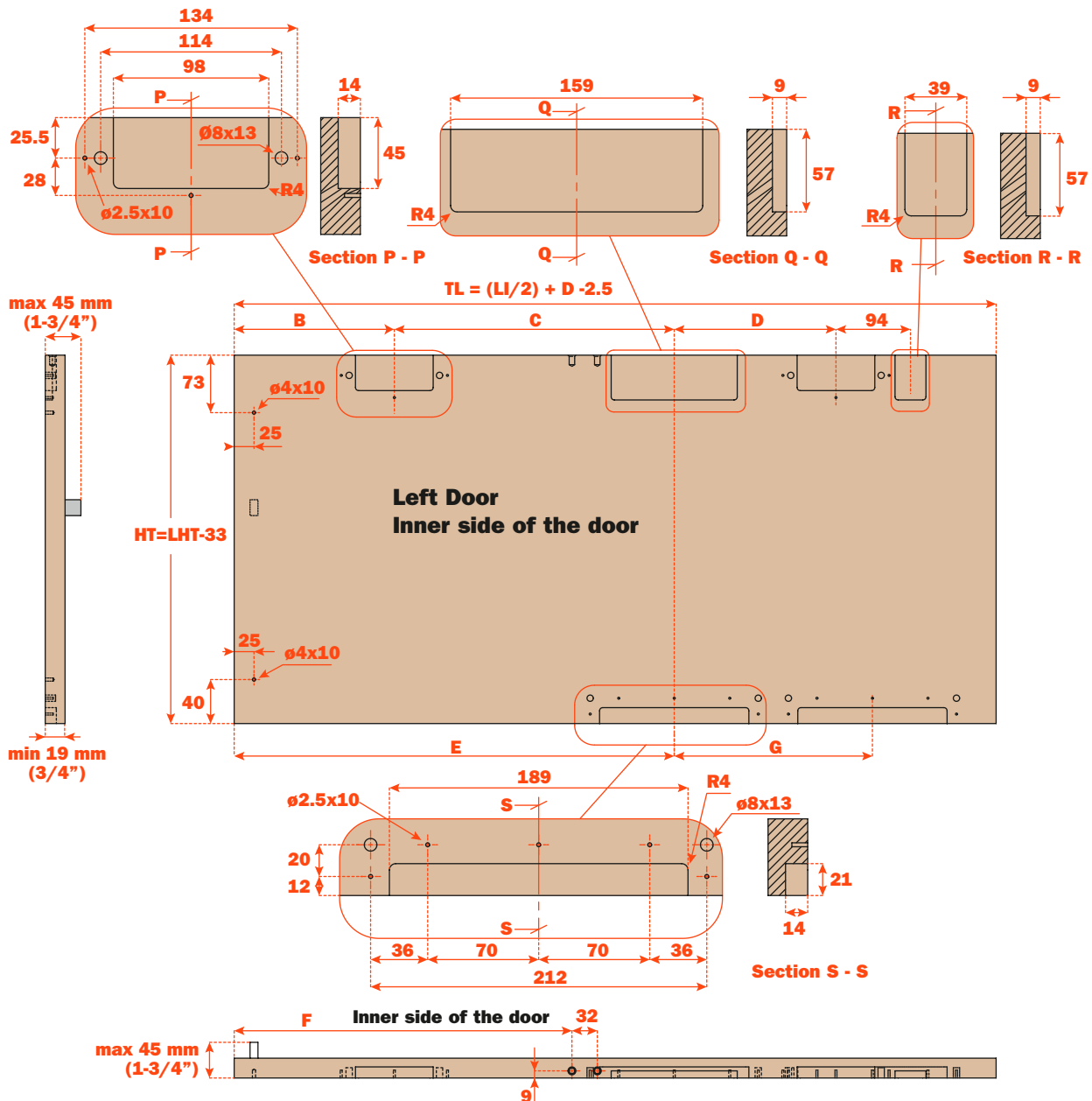

Product codes and assembly specifications RIGHT DOOR



As you are in the design phase it will be important to determine the weight of your doors and provide for it with adequate panels thickness.

CODE REFERENCES

- LI** Internal cabinet width
- TL** Door width
- LHI** Internal cabinet height
- SPI** Support panel thickness
- D** Door overlay on side panel
- TH** Door height
- B/C/D/E/F/G** See chart

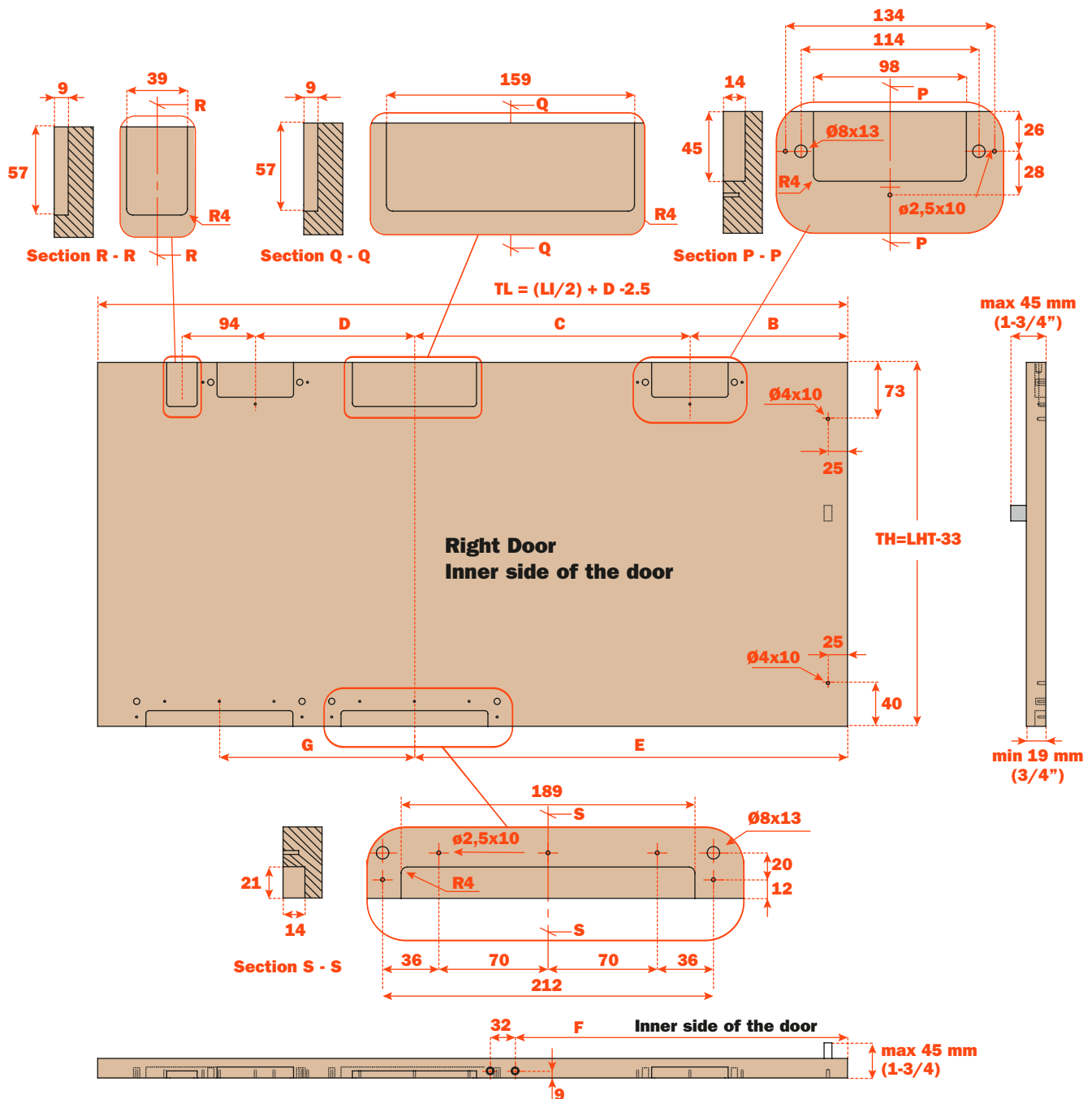

STANDARD 2 Doors

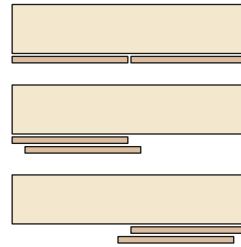

- **S10**
- **S20**
- **M35**
- **M35Top**
- **M50+**
- **L70**

ONE 1 Door



- **S10**
- **S20**
- **M35**
- **M35Top**
- **M50+**
- **L70**

ONE 1 Door



- **S10**
- **S20**
- **M35**
- **M35Top**
- **M50+**
- **L70**

STEP 2 Doors

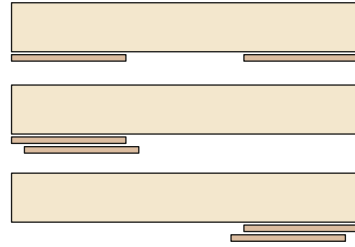

- **S20**
- **M35**
- **M35Top**
- **M50+**
- **L70**

REVERSO 2 Doors

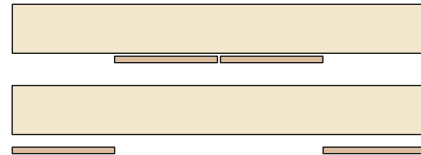

- **S10**
- **S20**
- **M35**
- **M35Top**
- **M50+**
- **L70**

STANDARD 3 Doors

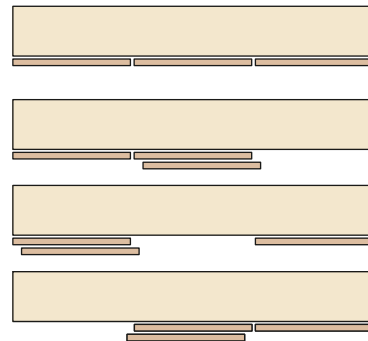

- **L70**