

Slider M50



Technical information

Coplanar two-door system with linear magnetic damper.

M50 is ideal for wardrobes and storage cabinets in offices and shops.

Individual door properties:

- max. weight per door: 50 Kg
- width: min. 800 mm max. 2000 mm
- height: min. 1200 mm max. 3000 mm

• thickness:

- with recessed upper adjuster
min. 18 mm, max. with handle 45 mm
- with external upper adjuster
min. 18 mm, max. with handle 40 mm

• material: wood

- Clipper frames can be used

Door adjustment:

- vertical adjustment ± 5 mm
- horizontal adjustment ± 3.5 mm
- front adjustment: - upper ± 3 mm
- lower ± 3 mm

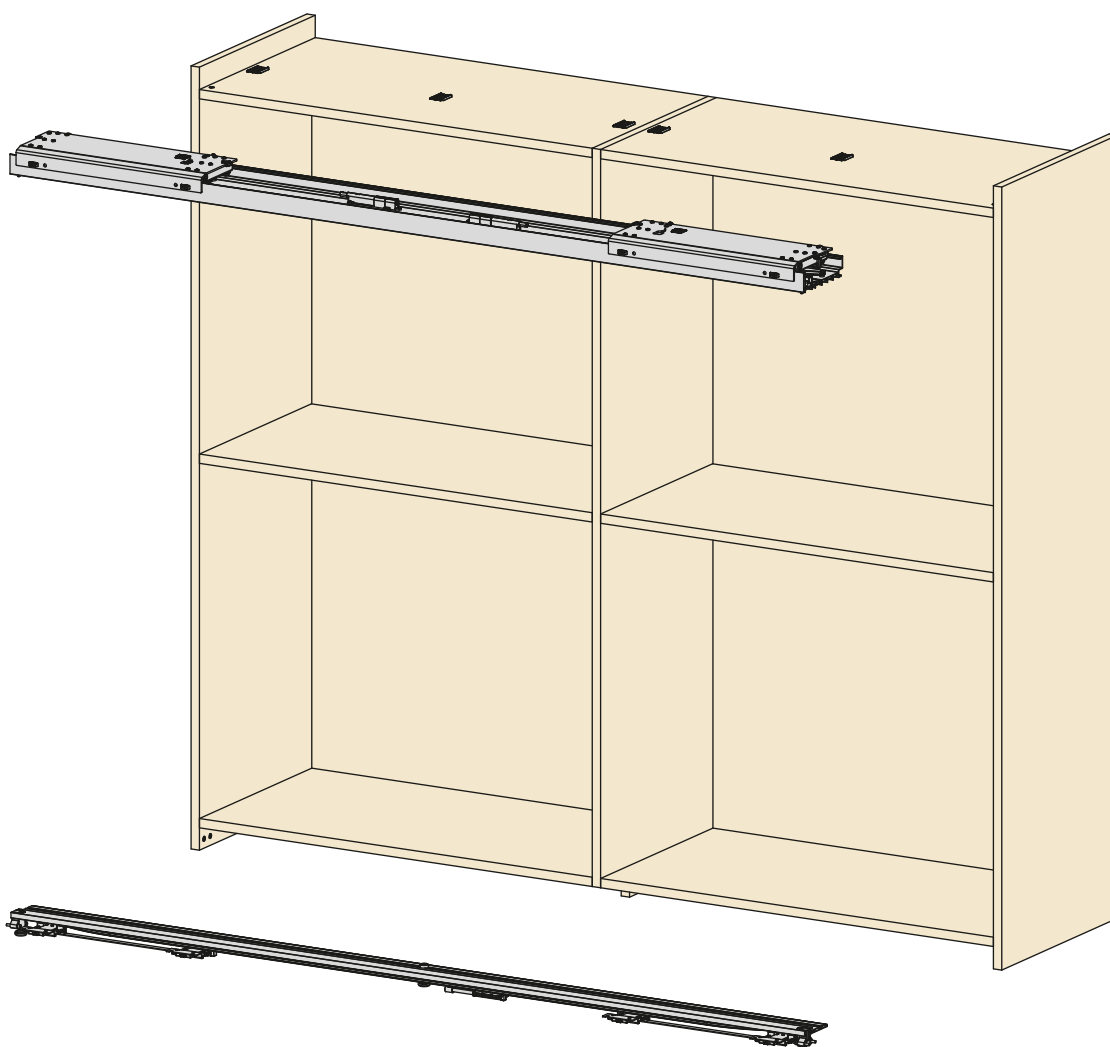





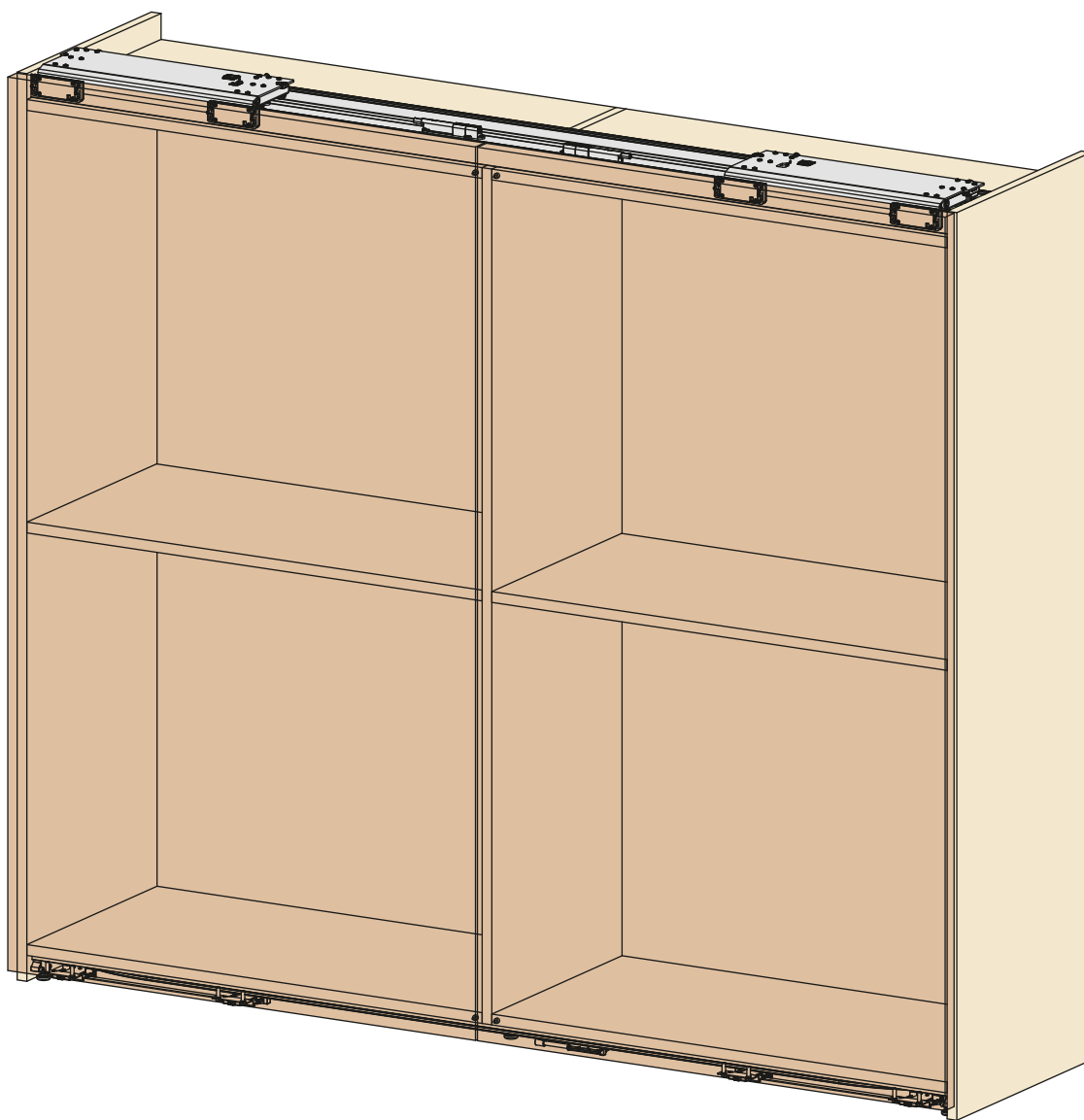



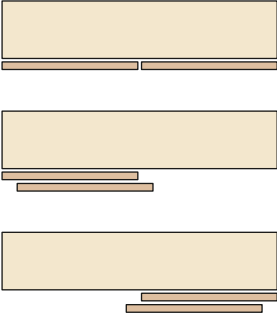

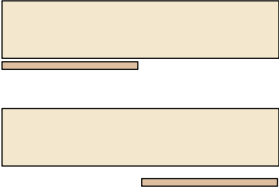
Key feature

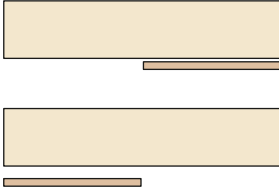
- Soft closing with magnetic technology.
- Very easy to assemble.
- Super-smooth cushioned opening and closing
- High reliability, tested to 100,000 cycles.

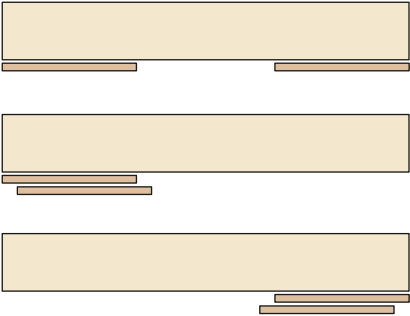

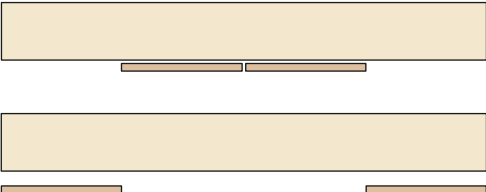
Slider M35 - M50 Available versions

<p>Standard</p>		<p>Slider M35 Slider M50</p>	 <p>Slider M35</p>
<p>One</p>		<p>Slider M35 Slider M50</p>	 <p>Slider M35</p>
<p>One</p>		<p>Slider M35 Slider M50</p>	 <p>Slider M35</p>
<p>Step</p>		<p>Slider M35 Slider M50</p>	 <p>Slider M35</p>
<p>Reverso</p>		<p>Slider M35 Slider M50</p>	 <p>Slider M35</p>