

## Slider M50



### Informazioni tecniche

Sistema di scorrimento complanare a due ante con ammortizzatore magnetico.

Per le sue caratteristiche, **M50** è l'ideale per gli armadi della zona notte e per i contenitori impiegati in ufficio e negli spazi commerciali.

### Caratteristiche ante:

- peso massimo per singola anta: 50 Kg
- larghezza: minimo 800 mm massimo 2000 mm
- altezza: minimo 1200 mm massimo 3000 mm

### • spessore:

- con regolatore superiore incassato minimo 18 mm, massimo con maniglia 45 mm
- con regolatore superiore esterno minimo 18 mm, massimo con maniglia 40 mm

### • materiale: legno

- si possono utilizzare telai Clipper

### Regolazione dell'anta:

- verticale  $\pm 5$  mm
- orizzontale  $\pm 3.5$  mm
- frontale: - superiore  $\pm 3$  mm  
- inferiore  $\pm 3$  mm

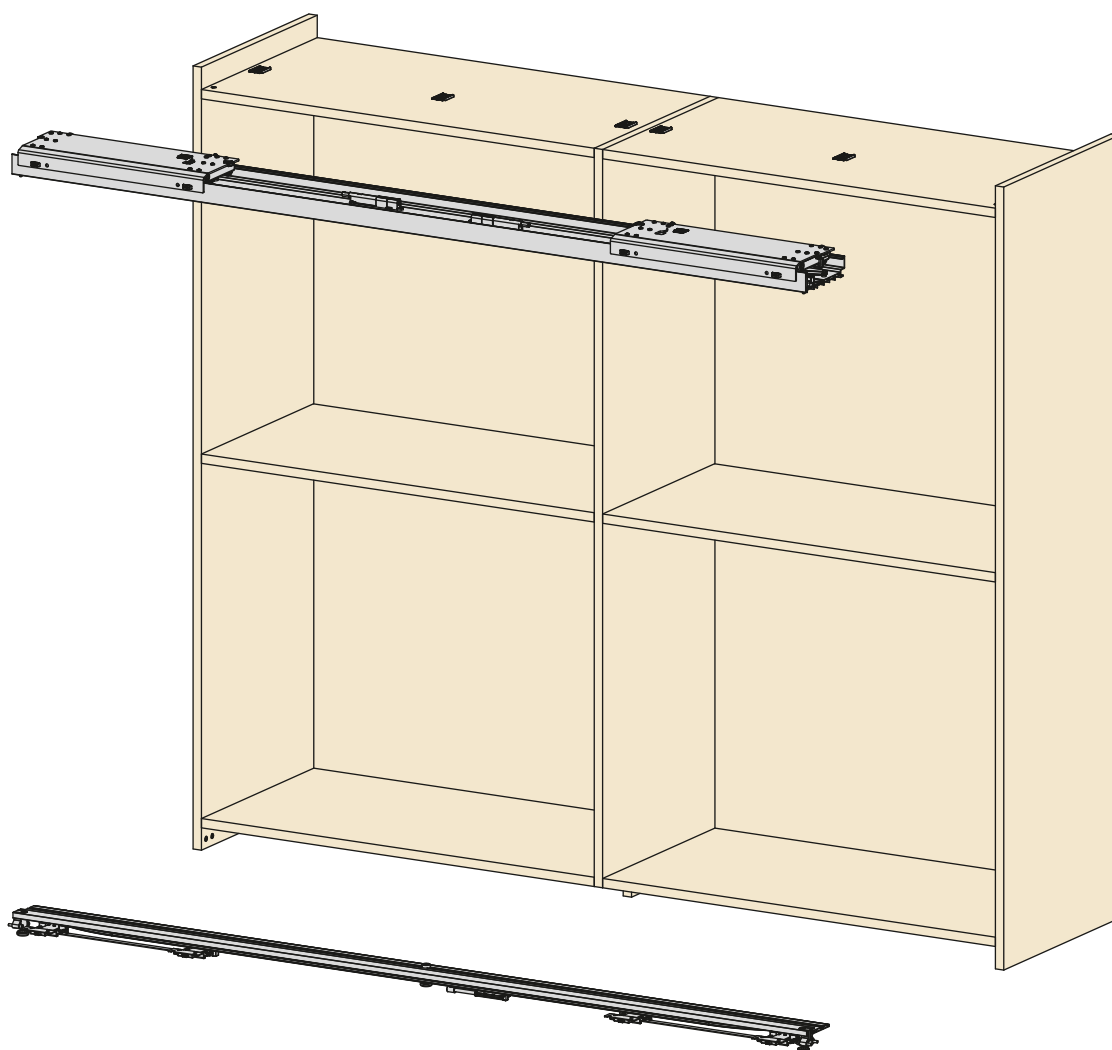





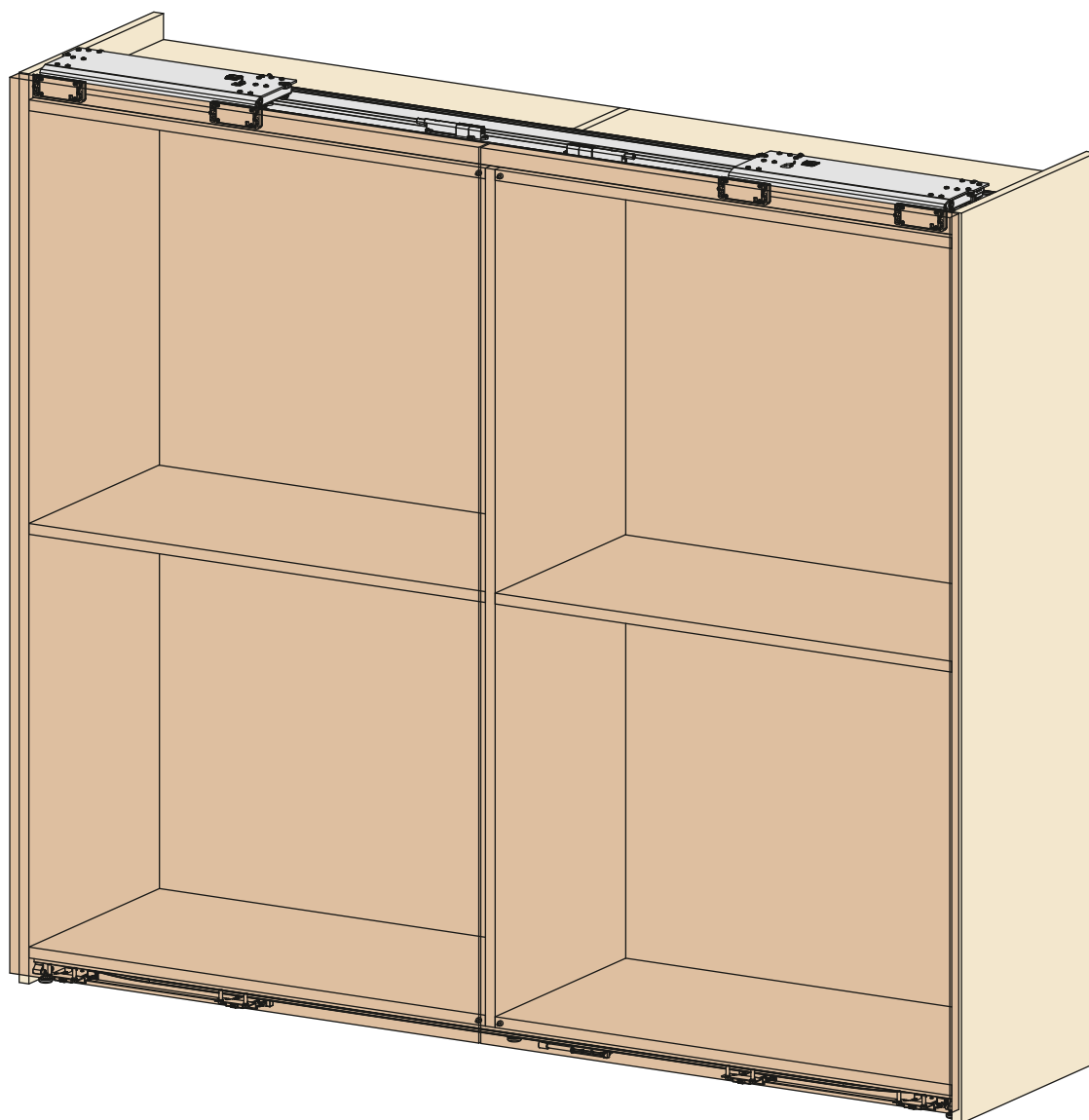



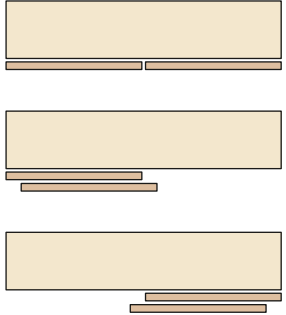

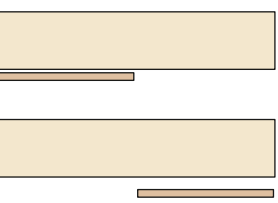
### **Caratteristiche principali**

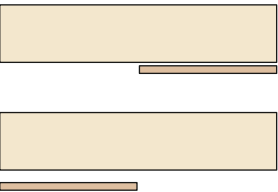
- Ammortizzazione con tecnologia magnetica.
- Massima semplicità di montaggio.
- Assoluta fluidità di scorrimento con ammortizzazione in apertura e chiusura.
- Elevata affidabilità, verificata con test di 100.000 cicli.

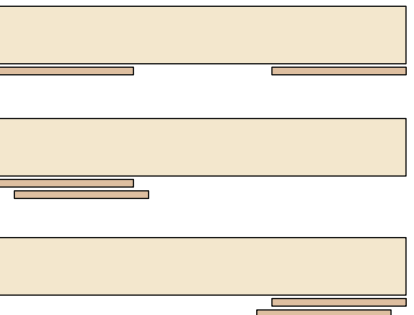

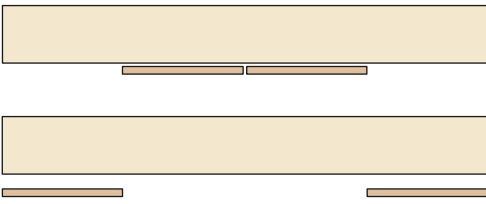
**Slider M35 - M50**    Versioni disponibili

<p><b>Standard</b></p>		<p><b>Slider M35</b> <b>Slider M50</b></p>	 <p><b>Slider M35</b></p>
<p><b>One</b></p>		<p><b>Slider M35</b> <b>Slider M50</b></p>	 <p><b>Slider M35</b></p>
<p><b>One</b></p>		<p><b>Slider M35</b> <b>Slider M50</b></p>	 <p><b>Slider M35</b></p>
<p><b>Step</b></p>		<p><b>Slider M35</b> <b>Slider M50</b></p>	 <p><b>Slider M35</b></p>
<p><b>Reverso</b></p>		<p><b>Slider M35</b> <b>Slider M50</b></p>	 <p><b>Slider M35</b></p>