



# Slider S20

Assembly instructions  
and order form



**Slider S20 - Base cabinet**



**Coplanar Sliding Door System for double door base cabinets with soft opening and soft closing feature.**

**Product overview**

- For wood or glass with aluminum-framed doors

**Tech features:**

- Max. weight capacity per door: 20 kg (44 lbs)
- Width of the door: min. 600 mm (23 - 5/8"), max. 1500 mm (59")
- Max. height of the door: 1200 mm (47 - 7/32")
- Thickness of the door: min. 19 mm (3/4"), max. 30 mm (1 - 3/16")
- Max. thickness of the door with handle: 45 mm (1 - 3/4")
- Min. distance of the handle from the edge of the door: 10 mm (3/8")
- Door height adjustment:  $\pm 4.5\text{mm}$  ( $\pm 3/16"$ )
- Door side adjustment:  $\pm 3\text{mm}$  ( $\pm 1/8"$ )
- Push release version kit available
- Available in single-door and/or custom width versions only upon request as a custom order.

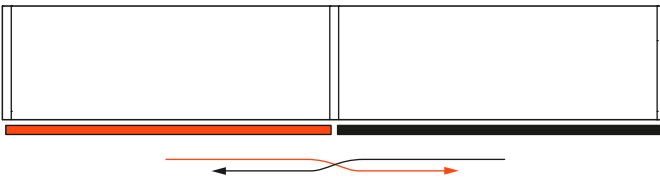

**System components**

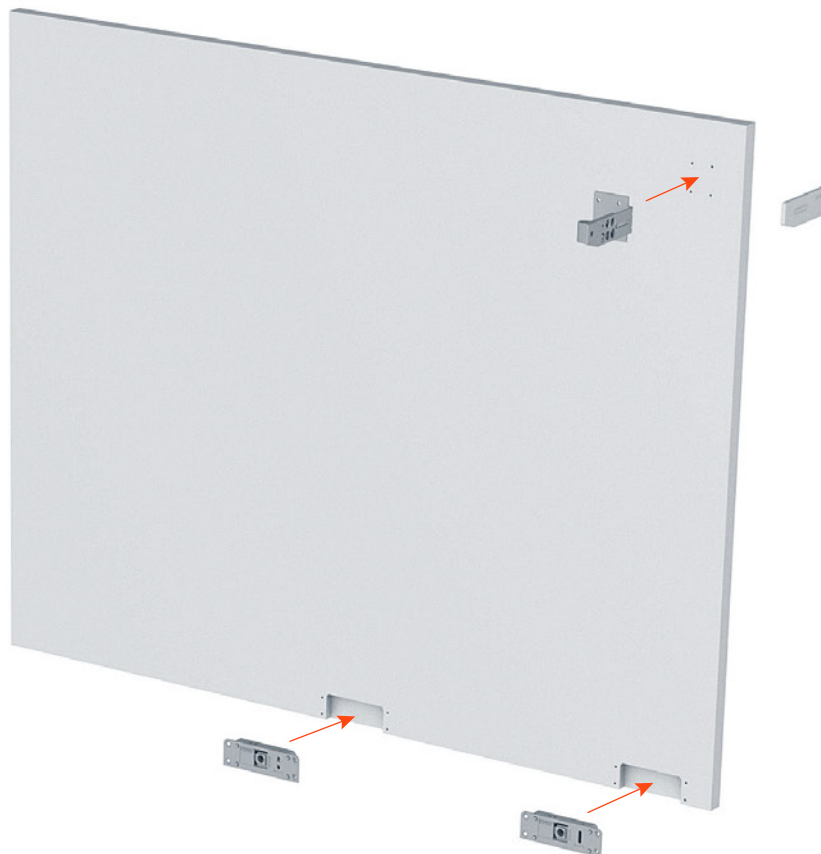

**Position the adjuster blocks on the doors**

**Upper guide track fixed under the top panel**

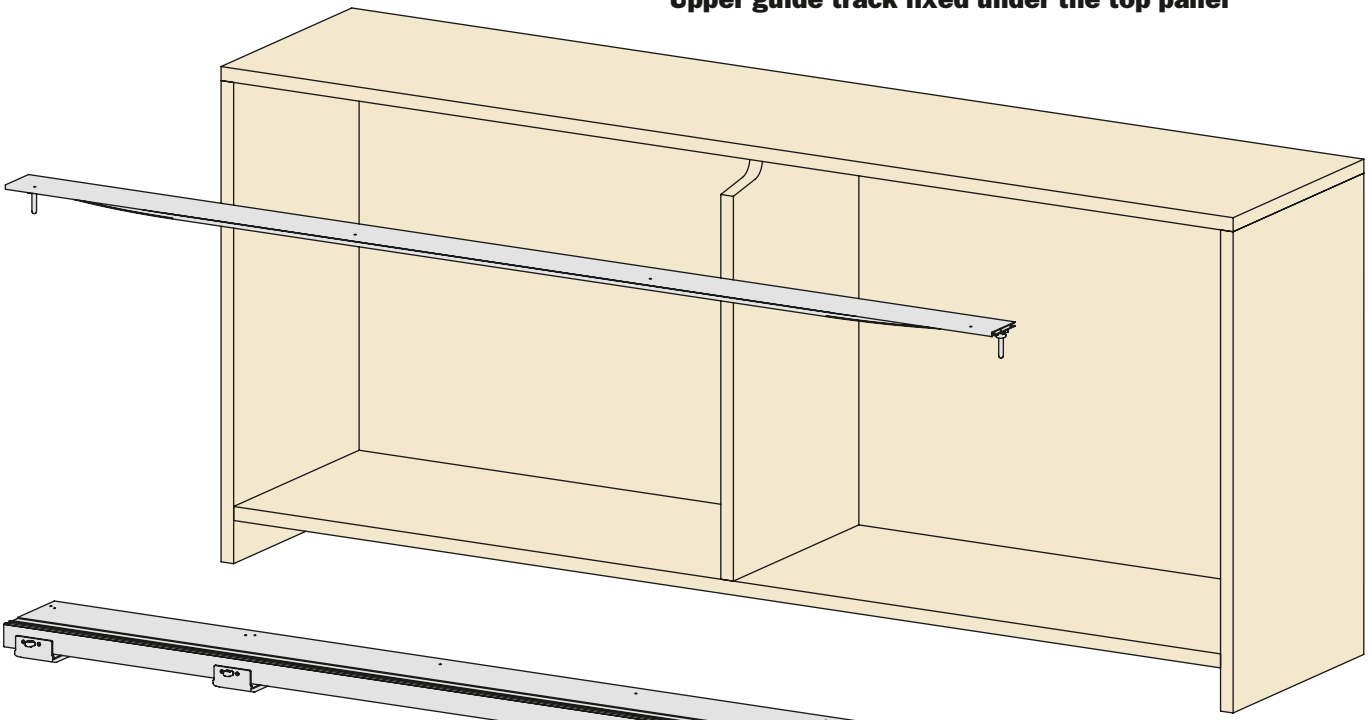

**Lower sliding mechanism fixed under the cabinet bottom**

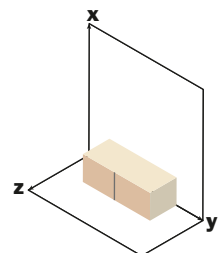

**Slider S20 - Base cabinet**

**CODE REFERENCES**

- LI** Internal cabinet width
- TL** Door width
- LHI** Internal cabinet height
- SPI** Central panel thickness
- D** Door overlay on side panel

- DC** Door overlay on top panel
- SPB** Bottom panel thickness
- TH** Door height
- A/B** See chart

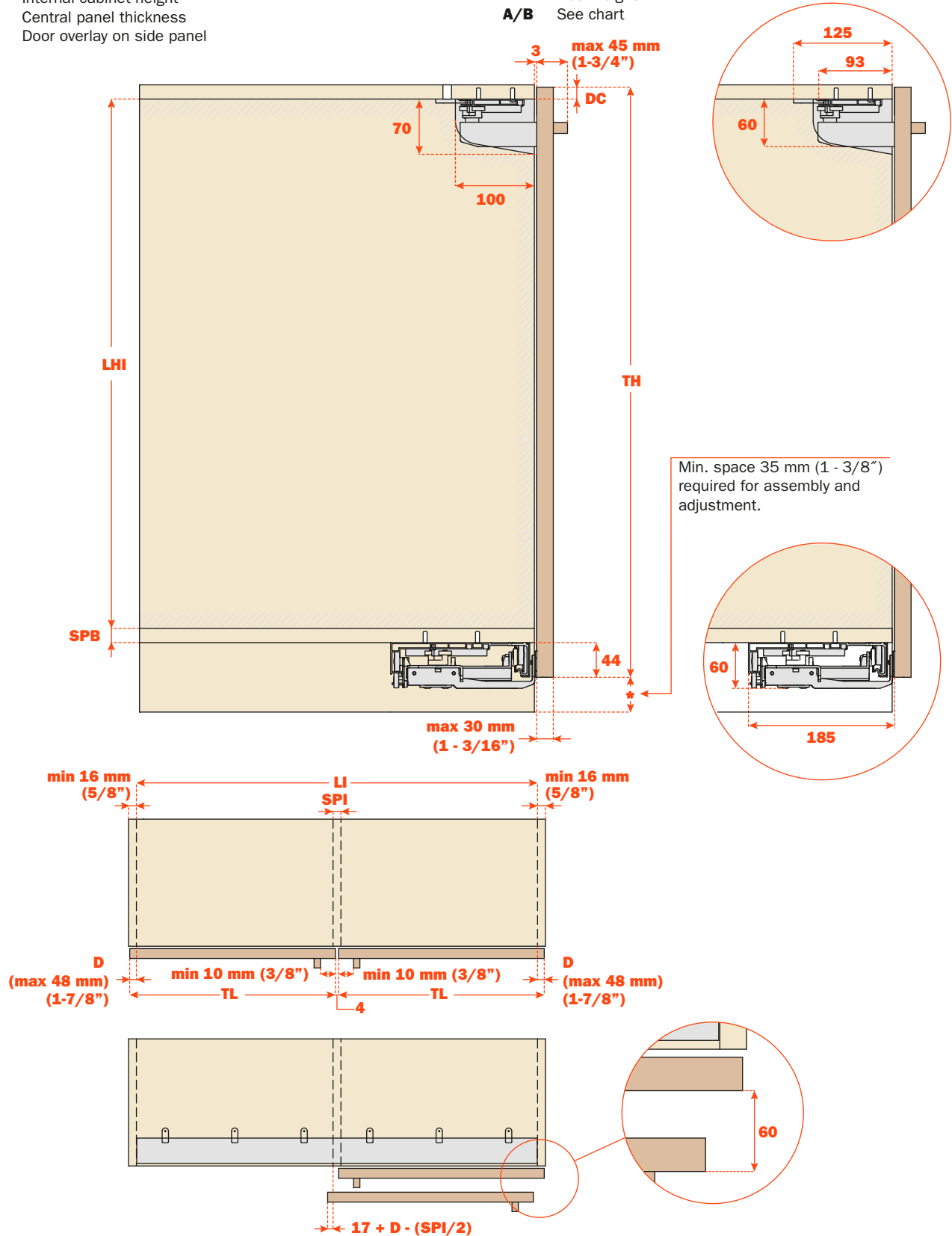

## Product codes and assembly specifications

Item	Mechanism Length mm	LI	Overlay (SAE) mm	A	B	Packaging	
						Weight kg	Dimensions cm
YE292AM1200SA	1161	1162	1 - 48	579	194.5	6.6	131 x 22 x 10
YE292AM1400SA	1361	1362	1 - 48	679	244.5	7.7	151 x 22 x 10
YE292AM1600SA	1561	1562	1 - 48	779	294.5	8.9	171 x 22 x 10
YE292AM1800SA	1761	1762	1 - 48	879	344.5	10	181 x 22 x 10
YE292AM2000SA	1961	1962	1 - 48	979	394.5	11	211 x 22 x 10
YE292AM2200SA	2161	2162	1 - 48	1079	444.5	11.9	231 x 22 x 10
YE292AM2400SA	2361	2362	1 - 48	1179	494.5	12.8	251 x 22 x 10
YE292AM2600SA	2561	2562	1 - 48	1279	544.5	13.8	271 x 22 x 10
YE292AM2800SA	2761	2762	1 - 48	1379	594.5	14.9	291 x 22 x 10
YE292AM3000SA	2961	2962	1 - 48	1479	644.5	15.9	311 x 22 x 10
YE29DM00048SU	1179	1180	1 - 48	588	199	8,1	135 x 20x8,5
YE29DM00060SU	1484	1485	1 - 48	740,5	275	10,4	166,4 x 20 x 8,5
YE29DM00072SU	1789	1790	1 - 48	893	351,5	11,4	197 x 20 x 8,5



As you are in the design phase it will be important to determine the weight of your doors and provide for it with adequate panels thickness.

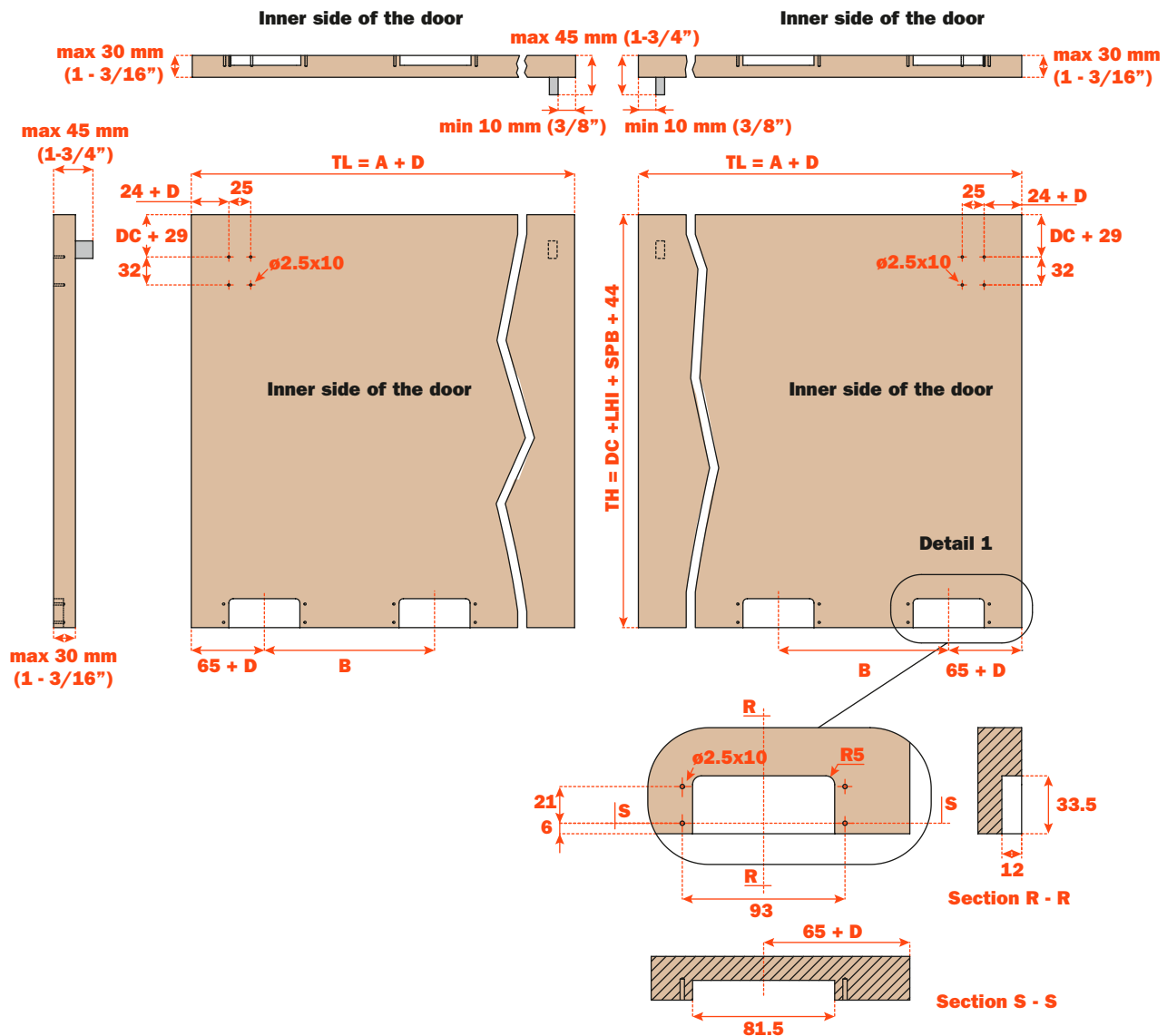

**STANDARD 2 Doors**

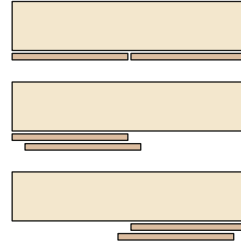

- **S10**
- **S20**
- **M35**
- **M35Top**
- **M50+**
- **L70**

**ONE 1 Door**

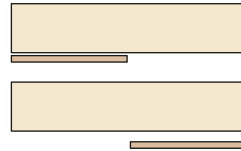

- **S10**
- **S20**
- **M35**
- **M35Top**
- **M50+**
- **L70**

**ONE 1 Door**



- **S10**
- **S20**
- **M35**
- **M35Top**
- **M50+**
- **L70**

**STEP 2 Doors**

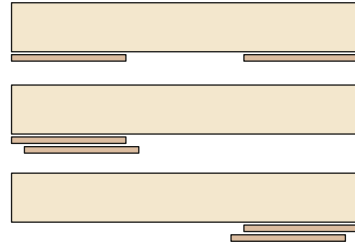

- **S20**
- **M35**
- **M35Top**
- **M50+**
- **L70**

**REVERSO 2 Doors**

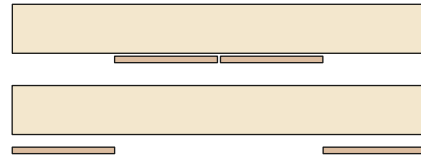

- **S10**
- **S20**
- **M35**
- **M35Top**
- **M50+**
- **L70**

**STANDARD 3 Doors**

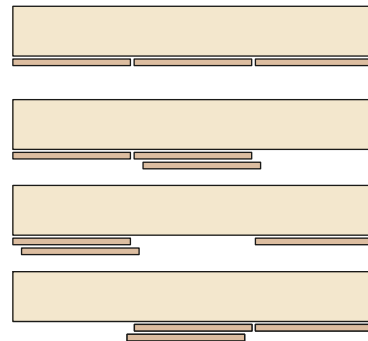

- **L70**