



# Slider S10

Assembly instructions  
and order form



**Slider S10 - Wall and base cabinet**

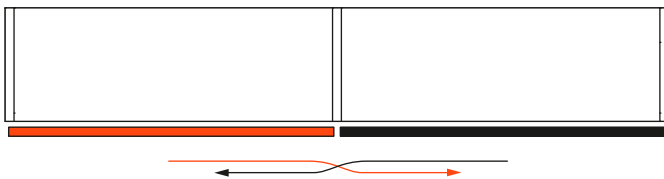

**Coplanar sliding door system for double door wall and base cabinets with soft opening and soft closing feature.**

**Product overview**

- For wood doors

**Tech features:**

- Max. weight capacity per door: 10 kg (22 lbs)
- Width of the door: min. 450 mm (17 - 11/16")  
max. 1200 mm (47 - 1/4")
- Max. height of the door: 800 mm (31 - 1/2")
- Thickness of the door: min. 16 mm (5/8")  
max. 30 mm (1 - 3/16")
- Max. thickness of the door with handle: 40 mm (1 - 9/16")
- Min. distance of the handle from the edge of the door: 10 mm (3/8")
- Door height adjustment:  $\pm 5.0$  mm ( $\pm 3/16$ ")
- Door side adjustment:  $\pm 2.5$  mm ( $\pm 1/8$ ")
- Door depth:
  - wall:  $\pm 2.0$  ( $\pm 1/16$ ")
  - base:  $\pm 2.5$  ( $\pm 1/8$ ")

**Wall Cabinet**

Mechanism attached to the top of the cabinet.

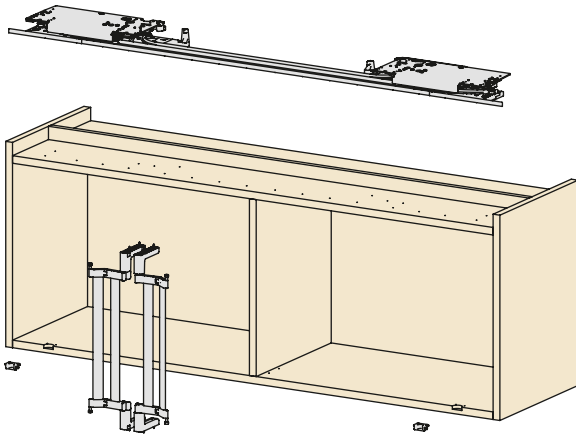

**Base Cabinet**

Upper guide track attached under the top panel.

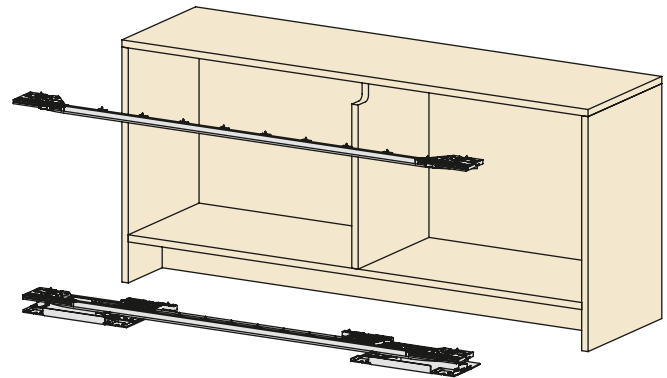

Mechanism attached under the bottom panel.

**KEY FEATURES:**

- Innovative sliding door system.
- Extremely easy to customize and assemble.
- Secured with screws. No need for machining the doors.
- Single-piece sliding track.
- Innovative suspended slider with double horizontal wheels.
- Soft opening and soft close feature.
- Full adjustment of the doors.

**CODE REFERENCES**

- LI** Internal cabinet width
- TL** Door width
- SPI** Center panel thickness
- D** Door overlay on side

# Wall Cabinet - Types of assembly

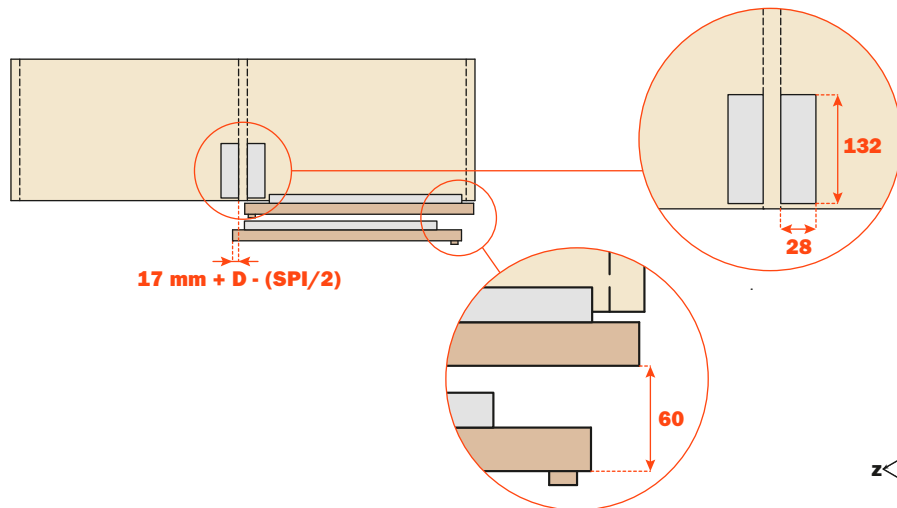
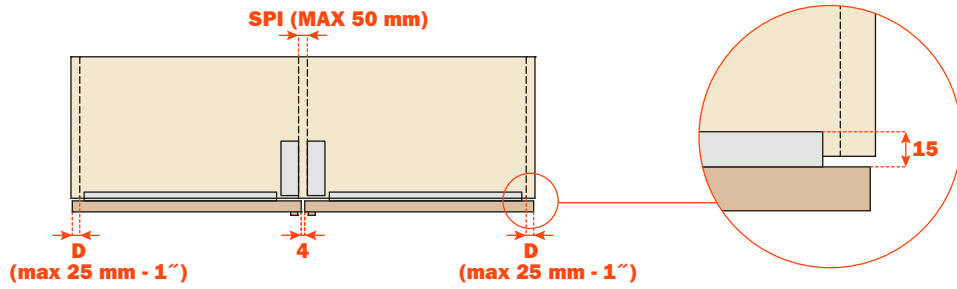
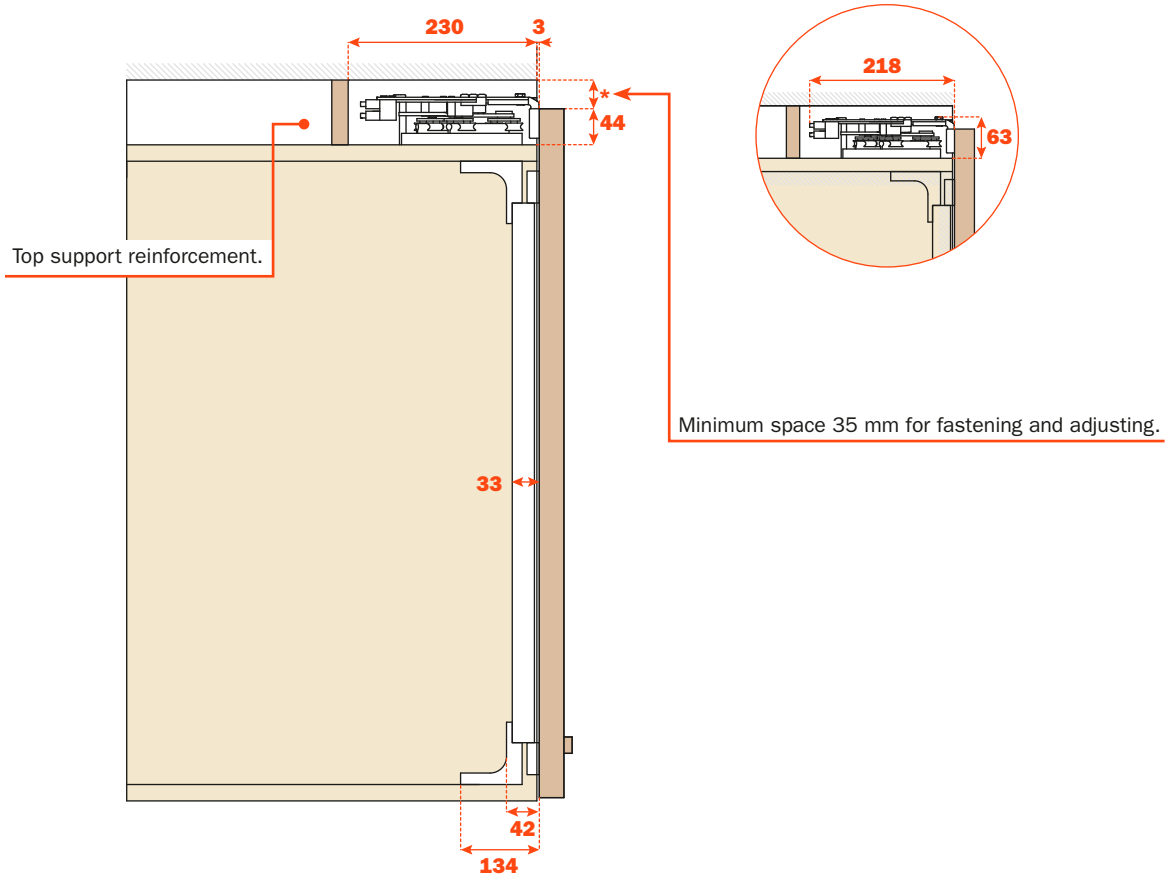

**Slider S10 - Types of assembly**

**Base Cabinet**

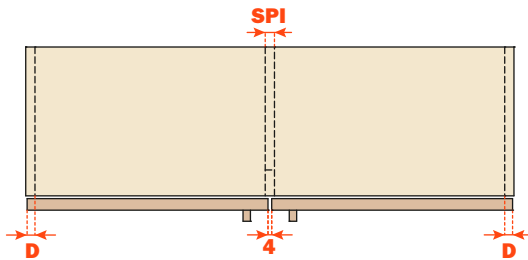
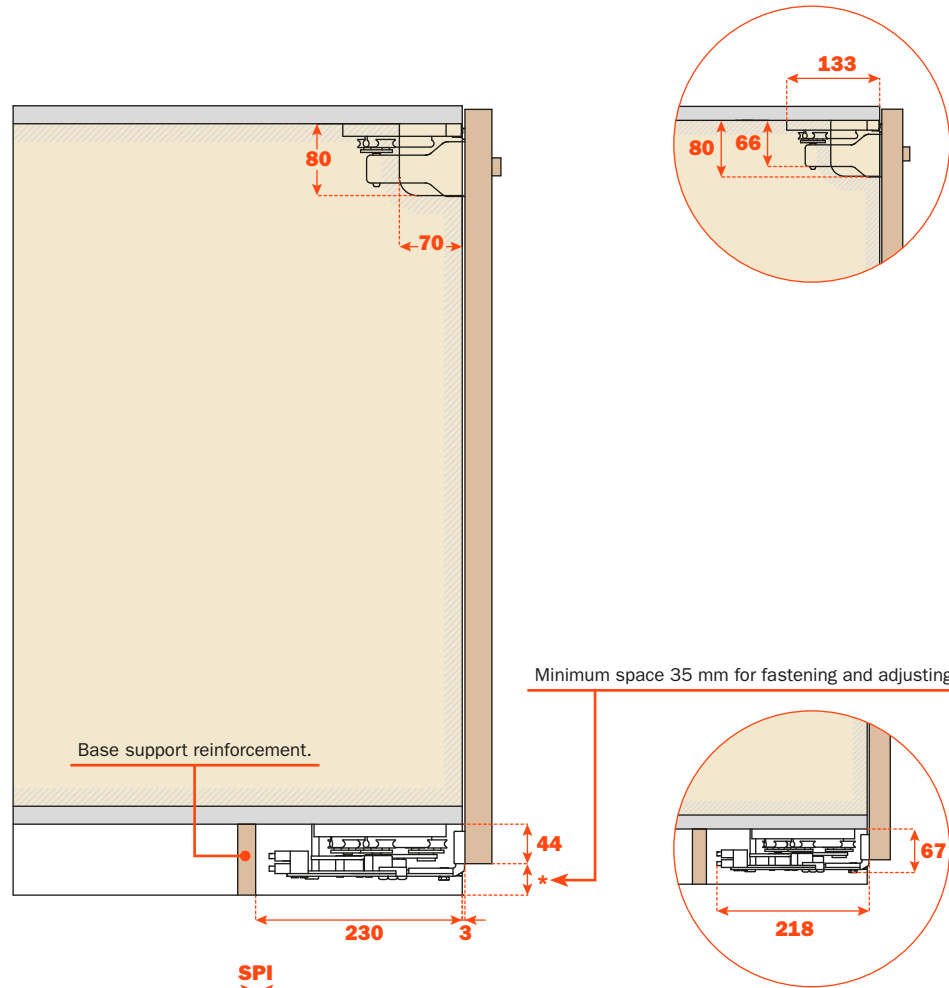

Single-piece sliding track.

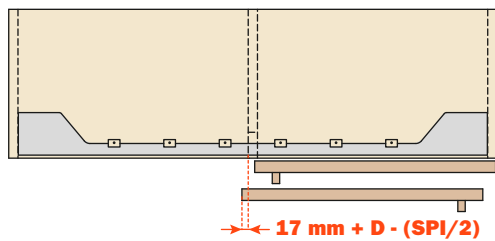

Two-piece sliding track  
(Only for custom orders).

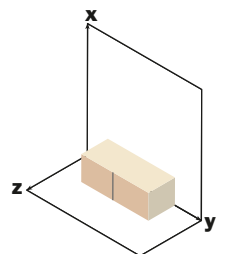
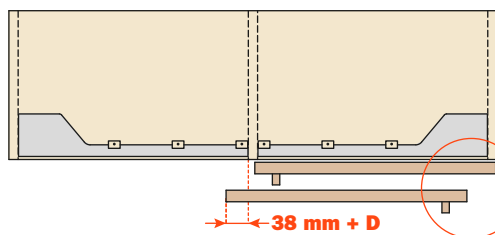

## Technical specifications

Slider S10 is a flexible system that can be adapted to the internal width of the cabinet (**LI**) with a minimum of 860 mm (33 - 7/8") to a maximum of 2400 mm (94 - 1/2").

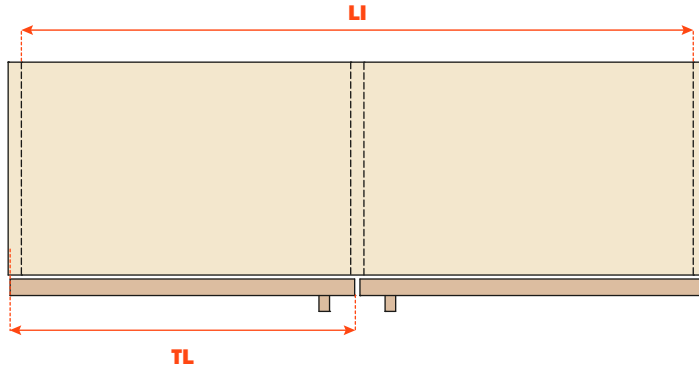

The handle must be positioned at a minimum 10 mm (3/8") from the edge of the door and a maximum of one third of its width (**TL**).

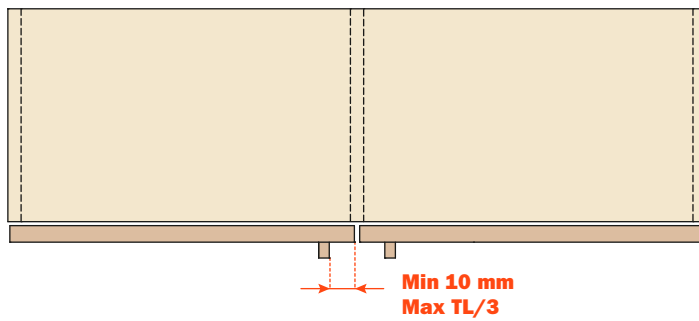

The maximum overlay on the side panel is 25 mm (1").

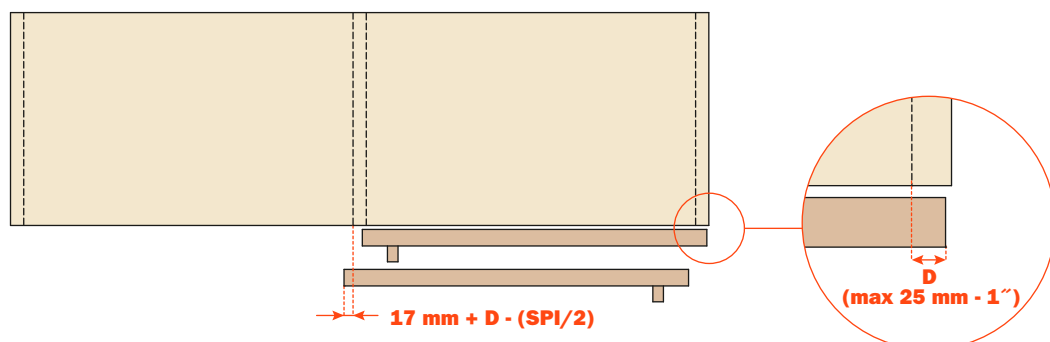

## Slider S10

The cabinet has to be constructed so that the bottom panel of the base unit, or the top panel of the wall unit is sufficiently rigid to prevent it from bending. For this reason, some reinforcement is always recommended **1**.

### Wall Cabinet

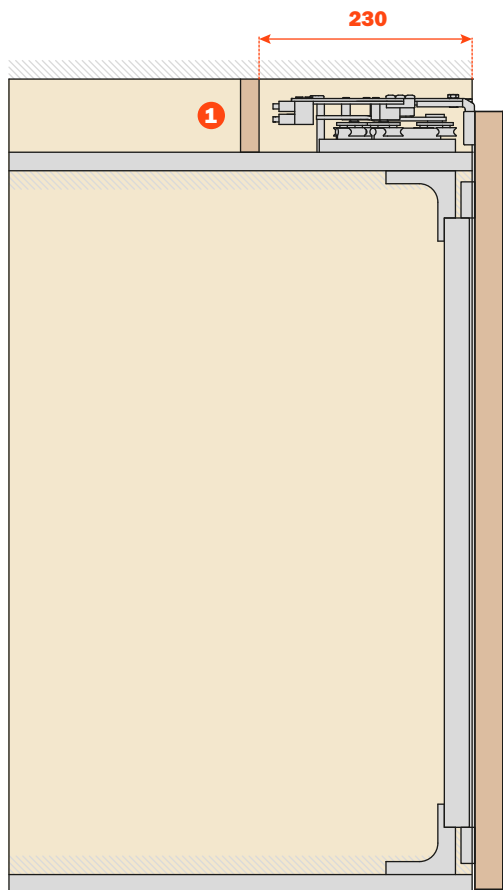

### Base Cabinet

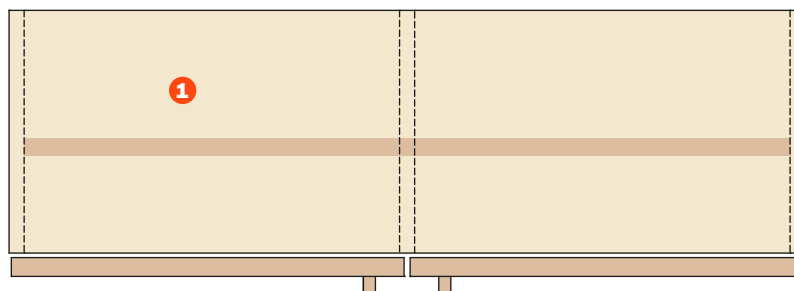
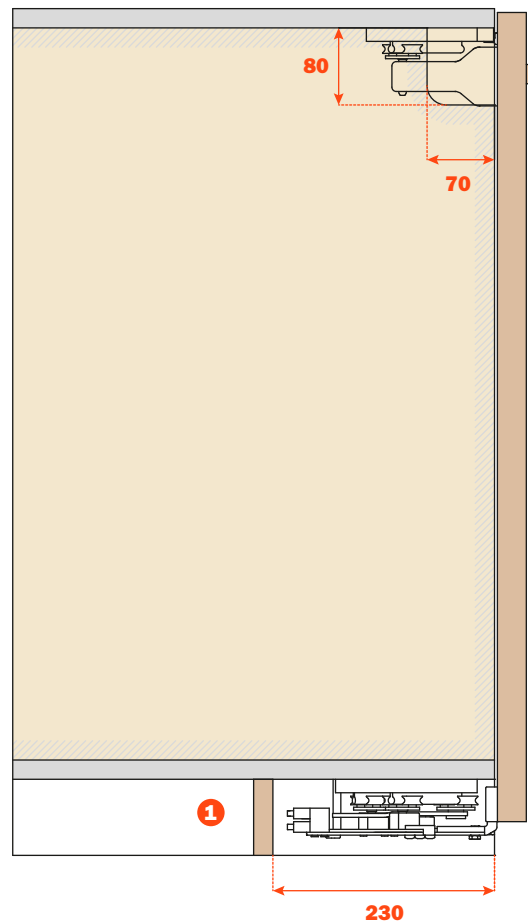

## Product codes

### Slider S10

A solution for a whole range of applications that requires the aluminum and PVC profiles to be measured and cut, and the mechanism assembled. Depending on the internal width of the unit (**LI**), the mechanism is put together using a carriage kit **1** and a profile kit **2** and base cabinet **M** or wall cabinet **P** accessories.

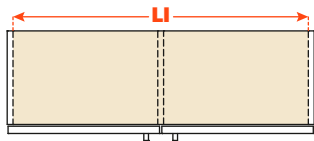

		LI (mm)						
		860 ÷ 987	988 ÷ 1115	1116 ÷ 1371	1372 ÷ 1627	1628 ÷ 1883	1884 ÷ 2139	2140 ÷ 2400
<b>M</b> <b>P</b>	<b>1</b>	YE57KIT0101	<b>M - P</b>					
		YE57KIT0102		<b>M - P</b>				
		YE57KIT0103			<b>M - P</b>			
		YE57KIT0104				<b>M - P</b>		
		YE57KIT0105					<b>M - P</b>	
		YE57KIT0106						<b>M - P</b>
		YE57KIT0107						
<b>M</b>	<b>2</b>	YE57KIT0201	<b>M</b>	<b>M</b>	<b>M</b>	<b>M</b>		
		YE57KIT0202					<b>M</b>	<b>M</b>
<b>P</b>	<b>2</b>	YE57KIT0301	<b>P</b>	<b>P</b>	<b>P</b>	<b>P</b>		
		YE57KIT0302					<b>P</b>	<b>P</b>

**Slider S10**
**Packaging details**

	<b>Weight (kg)</b>	<b>Volume (m<sup>3</sup>)</b>	<b>Dimensions (mm)</b>
YE57KIT0101	6,05	0,0212	470 x 300 x 150
YE57KIT0102	6,40	0,0225	500 x 300 x 150
YE57KIT0103	6,74	0,0240	535 x 300 x 150
YE57KIT0104	7,43	0,0270	600 x 300 x 150
YE57KIT0105	8,12	0,0297	660 x 300 x 150
YE57KIT0106	8,81	0,0326	725 x 300 x 150
YE57KIT0107	9,50	0,0355	790 x 300 x 150
YE57KIT0201	3,80	0,0252	1750 x 160 x 90
YE57KIT0202	4,30	0,036	2500 x 160 x 90
YE57KIT0301	4,80	0,0252	1750 x 160 x 90
YE57KIT0302	5,30	0,036	2500 x 160 x 90



**STANDARD 2 Doors**

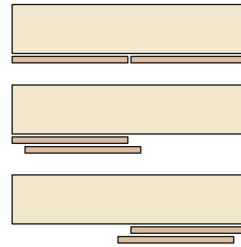

- **S10**
- **S20**
- **M35**
- **M35Top**
- **M50+**
- **L70**

**ONE 1 Door**

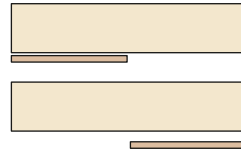

- **S10**
- **S20**
- **M35**
- **M35Top**
- **M50+**
- **L70**

**ONE 1 Door**



- **S10**
- **S20**
- **M35**
- **M35Top**
- **M50+**
- **L70**

**STEP 2 Doors**

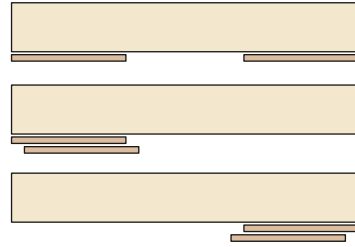

- **S20**
- **M35**
- **M35Top**
- **M50+**
- **L70**

**REVERSO 2 Doors**

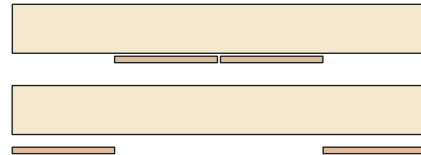

- **S10**
- **S20**
- **M35**
- **M35Top**
- **M50+**
- **L70**

**STANDARD 3 Doors**

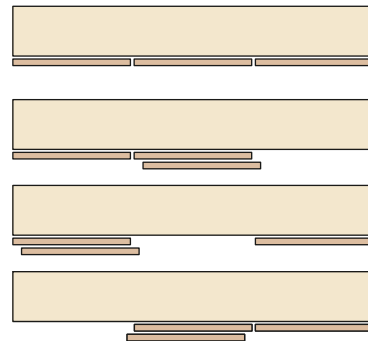

- **L70**