

EvoLift • Flap door opening system
Magnetic Push - Recessed magnetic release device and retaining catches

DPMSNB - beige

Magnetic catch
 ø 10 mm, 40 mm length.



DPASNB - beige

Optional supplementary magnetic catch to increase the holding strength. It must always be used together with the DPM.
 The suggested position of the DPM is the point of pressure on the door. The DPA can be positioned at any point along the opening edge of the door.
 ø 10 mm, 40 mm length.



DPMSNG - grey



Packaging
 Boxes 250 pcs.
 Cartons 1.500 pcs.

DPASNG - grey



Packaging
 Boxes 250 pcs.
 Cartons 1.500 pcs.

DP39XXG

Adjustable magnetic retaining catch.
 ø16.6 mm



Packaging • Boxes 250 pcs.

DP28SN9

Pin-attach striker for magnetic catches.
 ø 11.5 mm.



Packaging • Boxes 250 pcs.

DP38XX91

Self-adhesive striker for magnetic catches.
 20x14 mm.



Packaging • Boxes 250 pcs.

The Push self-opening system is recommended for doors up to a max. 400 mm in height.

DP39 / DP28 / DP38

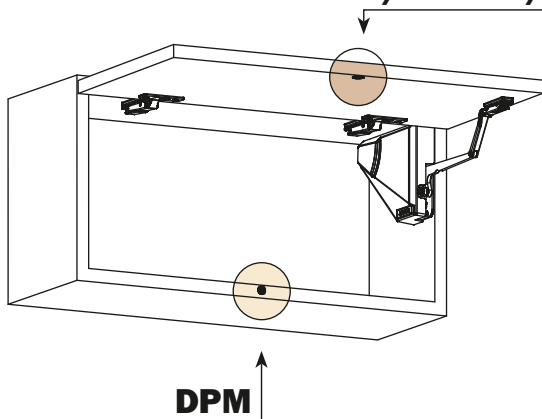

DP39 / DP28 / DP38

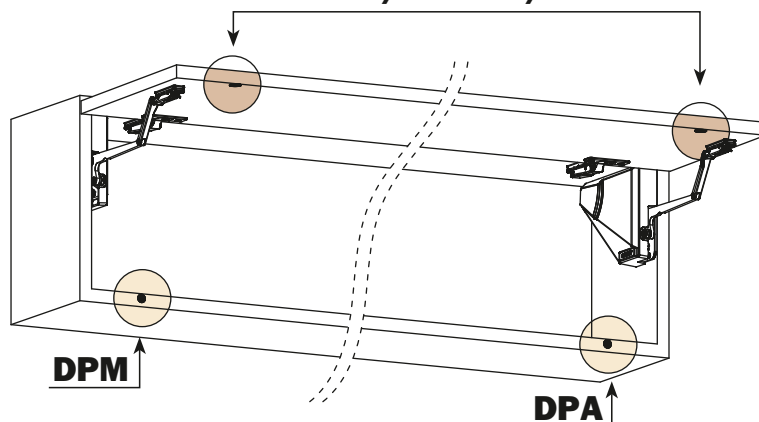

Release device application

Application of the standard magnetic catch.

Drill a hole \varnothing 10 mm and min. 40 mm depth in the top, the side or the base panel of the cabinet.

Insert the release device into the hole.

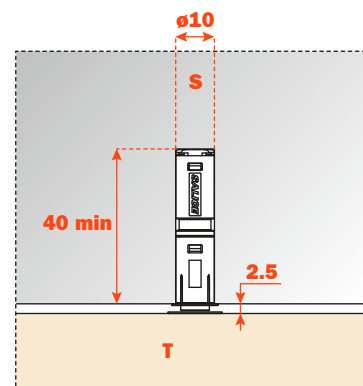

Inserted adjustable magnetic catch.

The retaining catch DP39 is itself magnetic and together with the magnetism of the release device DPM considerably increase (30%) the holding strength of the door against the cabinet side, thus avoiding accidental openings.

For the installation it is necessary to drill a hole \varnothing 15 mm and 11 mm depth in the door.

Depth adjustment from -0.5 mm to +2.5 mm.

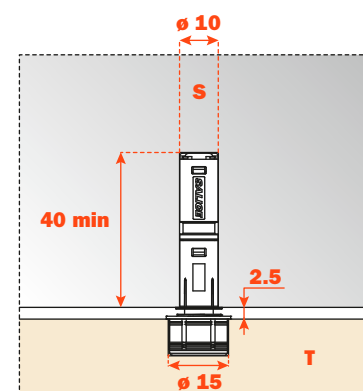

Pin-attach striker.

Apply the retaining catch to the magnetic release device.

Close the door.

The point of the retaining catch will show where to insert it.

Reopen the door and drive in the pin to attach in position.

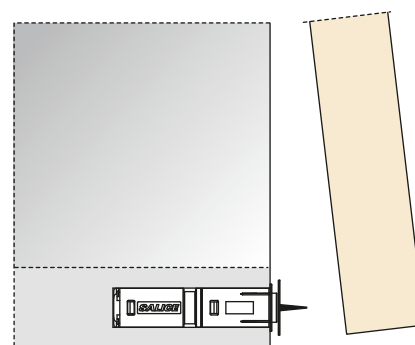

Self-adhesive striker.

Apply the retaining catch to the magnetic release device. Remove the protective strip from the adhesive. Close the door. In this way the retaining catch is positioned on the door. Reopen the door and apply a firm pressure to the retaining catch to ensure a correct installation.

ATTENTION:

For a correct application and to ensure optimal endurance, we suggest these guidelines are followed:

- 1 - clean and degrease the door surface where the retaining catch is to be installed;
- 2 - remove the protective strip from the adhesive;
- 3 - place the retaining catch in position, in a place that is at room temperature $\geq 10^\circ$ and apply a firm pressure for 10-15 seconds.

After few seconds from the installation the retaining catch is suitable for the use.

After 24h the max. hold is attained.

