

## Technical information

### Flap door lift system fixed to the cabinet sides.

Drilling of the door  $\varnothing 35$ .  
 13 mm deep cup.  
 85° opening with stop device (premounted).  
 94° opening without stop device.  
 Possible drilling distance on the door (K): from 3 to 7 mm.

## Drilling patterns.

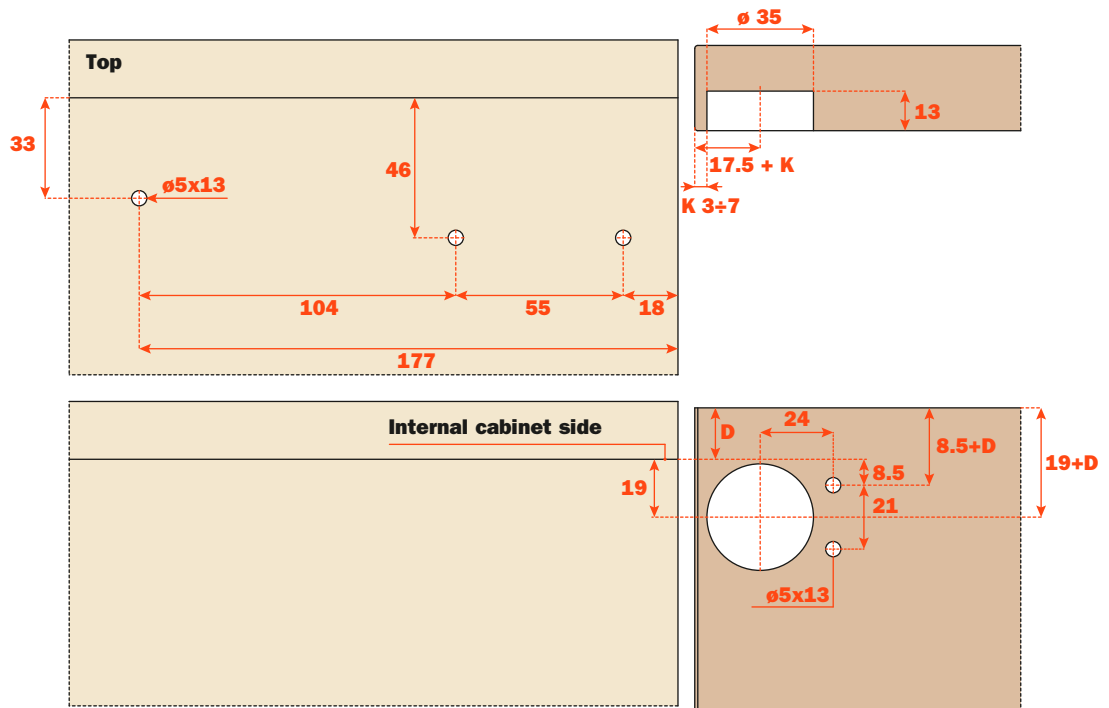

## Space needed to open the door.

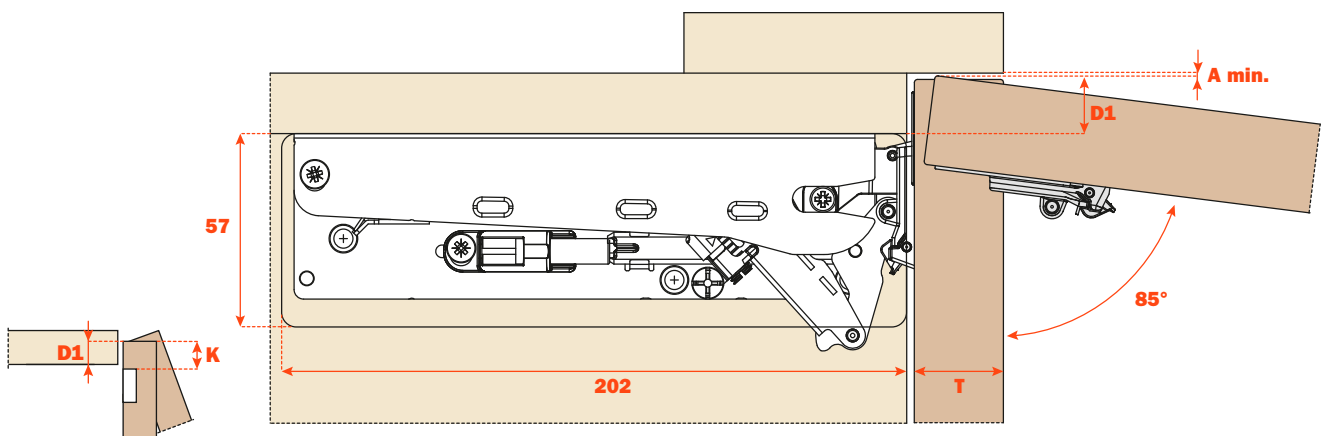

K	D1
3	= 16
4	= 17
5	= 18
6	= 19
7	= 20

	T=	16	17	18	19	20	21	22	23	24	25	26	27	28
K=3	<b>A = min</b>	0	0.1	0.1	0.2	0.2	0.3	0.5	0.6	0.7	0.9	1.1	1.8	2.7
K=4	<b>A = min</b>	0	0.1	0.1	0.2	0.2	0.3	0.4	0.6	0.7	0.9	1.1	1.3	2.1
K=5	<b>A = min</b>	0	0.1	0.1	0.2	0.2	0.3	0.4	0.6	0.7	0.9	1.1	1.3	1.5
K=6	<b>A = min</b>	0	0.1	0.1	0.2	0.2	0.3	0.4	0.6	0.7	0.9	1.0	1.2	1.5
K=7	<b>A = min</b>	0	0.1	0.1	0.2	0.2	0.3	0.4	0.6	0.7	0.8	1.0	1.2	1.4