

**Compact, elegant, very strong mini hinge.
Bright nickel plated steel cup and arm.
Dimensions of the ø 26 mm cup.**

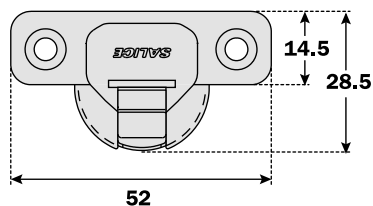

Constant "L" value of 0.7 mm (it does not change during side adjustment).

Approx. number of hinges required according to the door dimension and weight.

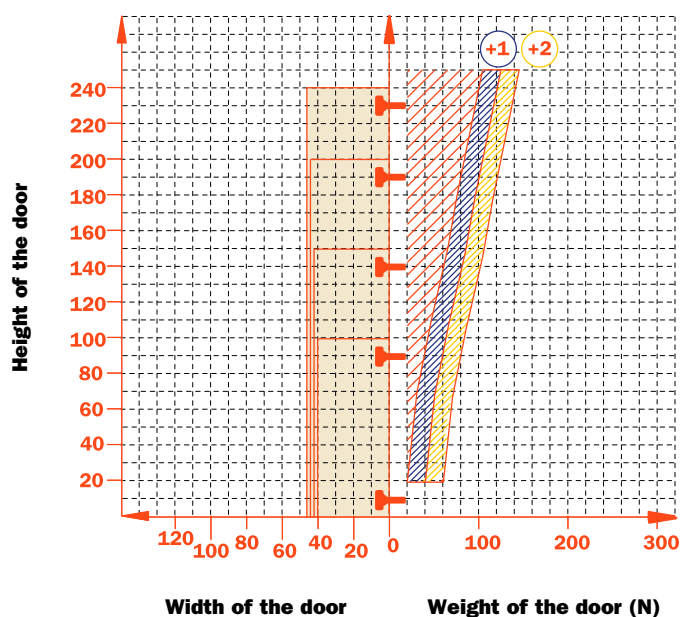

Adjustments

Side adjustment +5 mm. It is possible to recover the gap behind the door (the initial "L" value of 0.7 mm) simply by using the assembly stop located on the underside of the hinge.
Height adjustment ± 2 mm.
Depth adjustment with Series 200 mounting plates +2.5 mm.

Mounting plates

Symmetrical and asymmetrical bright nickel plated steel or die-cast Series 200 mounting plates.
Positioning with pre-determined stop on Series 200 traditional mounting plates.
NOT COMPATIBLE with Series 200 mounting plates with negative height.

N.B. : Use POZIDRIVE No. 2 screwdrivers for all screws.

| | | |
|-------------------|----------|----------|
| | | |
| <p>Wood screw</p> | <p>A</p> | |
| | | |
| <p>Dowel</p> | <p>B</p> | <p>R</p> |

Use this table to identify the available drillings and fixings.

Fill the third position of the hinge code number with the letter or the number corresponding to your choice. I.e.: C6_7C99.

↑
Fill this position with the chosen letter or number.

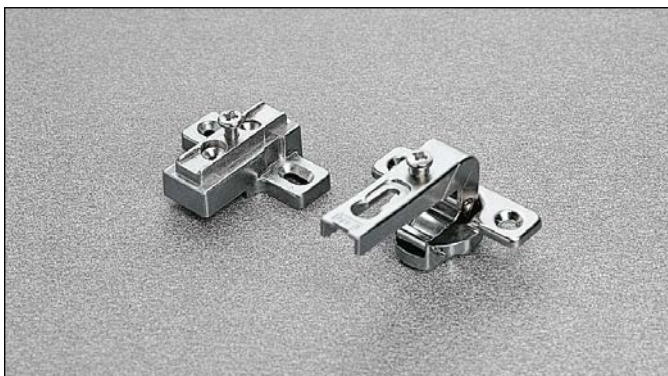

Technical information

Crampon hinges.

For smaller spaces with 15x32 mm drilling.

11.5 mm deep metal cup.

94° opening.

Possible drilling distance on the door (K): from 3 to 8 mm.

Compatible with all traditional Series 200 mounting plates, 28x32 mm drilling.

NOT COMPATIBLE with Domi snap-on mounting plates.

Packing

Boxes 300 pcs.

Pallets 7.200 pcs.

Use the tables "Drillings and fixings" at page 11 to complete the code number of the desired hinge.

CA sprung hinge

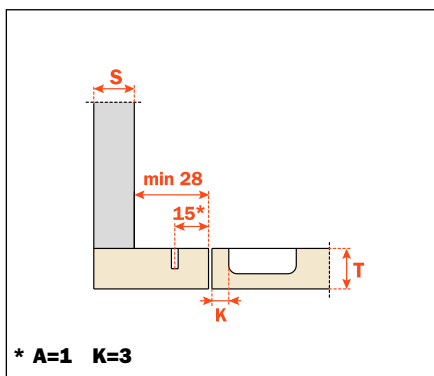
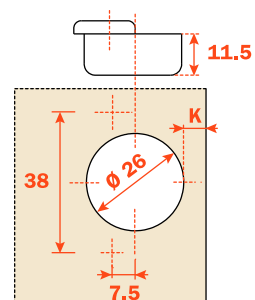

CA - C6_7N99

Heights of mounting plates for every assembly.

