

Silentia • Series 800

Hinges with adjustable integrated soft-close mechanism operated by twin silicone-oil dampers housed in the hinge cup.

The decelerating effect is adjusted by using a simple switch.

Bright nickel plated steel cup and arm.
Dimensions of the Ø 35 mm cup.

Technical features

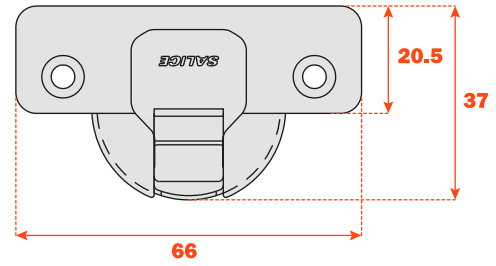

Approx. number of hinges required according to the door dimension and weight.

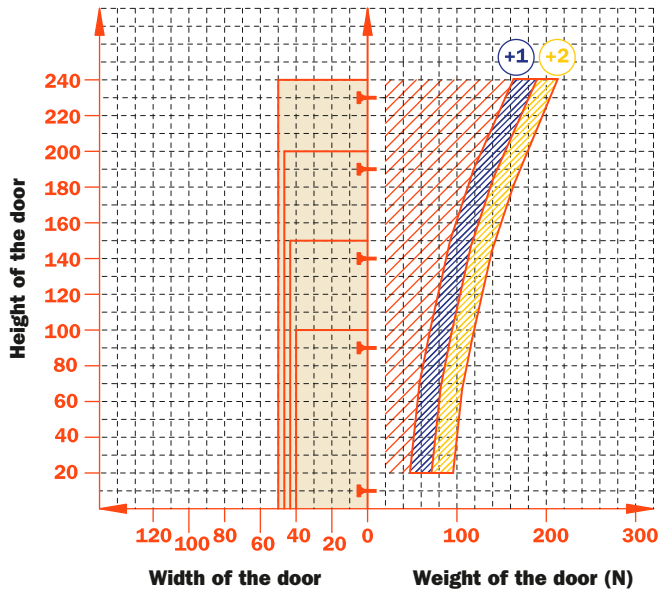

Adjustments

Side adjustment from -1.5 mm to +4.5 mm.
Height adjustment ±2 mm.
Depth adjustment from -1.5 mm to +3 mm.

Mounting plates

Symmetrical and asymmetrical bright nickel plated steel Series 200 mounting plates.
NOT COMPATIBLE with Series 200 mounting plates with negative height.

N.B. : Use POZIDRIVE No. 2 screwdrivers for all screws.

Drillings and fixings

Wood screw		A	P	U
Rapido		6	7	2
Dowel		B	R	W

Use this table to identify the available drillings and fixings.

Fill the third position of the hinge code number with the letter or the number corresponding to your choice. I.e.: C8_6CE9.



Fill this position with the chosen letter or number.

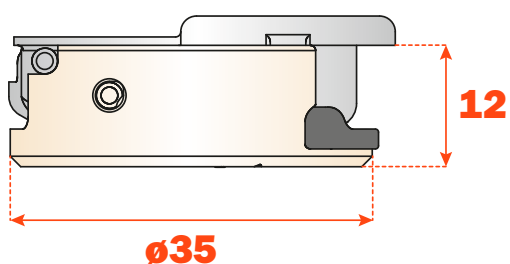

105° opening

Silentia • Series 800 • 105° opening



Technical information

Hinges with adjustable integrated soft-close mechanism operated by twin silicone-oil dampers housed in the hinge cup. The decelerating effect is adjusted by using a simple switch.

Hinges for doors of small weight and thickness.

12 mm deep cup.

105° opening.

Possible drilling distance on the door (K): from 3 to 6 mm.

Compatible with all traditional steel Series 200 mounting plates.

Space needed to open the door

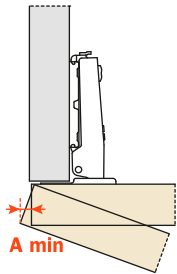

	T=	15	16	17	18	19	20
K=3	A=	1.0	1.0	1.2	1.4	1.6	1.9
K=4	A=	0.9	1.0	1.2	1.3	1.5	1.8
K=5	A=	0.9	1.0	1.1	1.2	1.5	1.8
K=6	A=	0.9	1.0	1.1	1.2	1.4	1.7

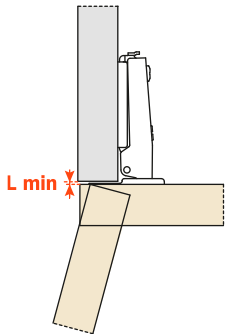

	T=	15	16	17	18	19	20
K=3	L=	0.0	0.0	0.0	0.0	0.1	0.3
K=4	L=	0.4	0.6	0.7	0.9	1.1	1.2
K=5	L=	1.0	1.0	1.2	1.8	2.0	2.0
K=6	L=	1.6	1.8	2.0	2.1	2.3	2.5

The above values are calculated on the assumption that the doors have square edges. They are reduced if the doors have radiussed edges.

Projection of the door

Projection of the door from the cabinet side at the max. opening. The figures are based on a straight arm hinge, H=0 mm thickness of mounting plate and K value = 3 mm.

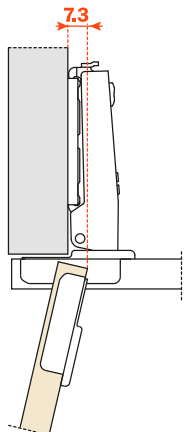

“C” value

With this formula you can obtain the max. thickness of the moulded door that can be opened without touching adjacent carcass sides, doors or walls, whilst bearing in mind the above L · K · T values.

$$C = 20.5 + K + A$$

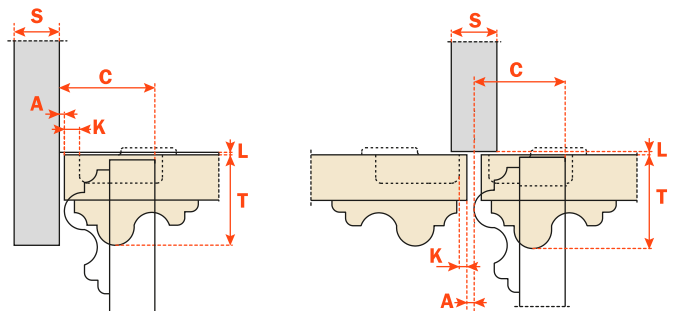

Packing • Boxes 300 pcs. • Pallets 7.200 pcs.

Use these formulas to determine the type of hinge arm, the drilling distance "K" and the height of the mounting plate "H" which is necessary to solve each application problem.

Use the tables "Drillings and fixings" at page 59 to complete the code number of the desired hinge.

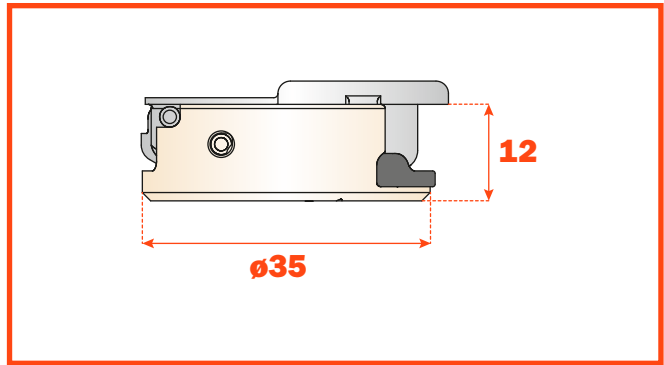

Arm 0

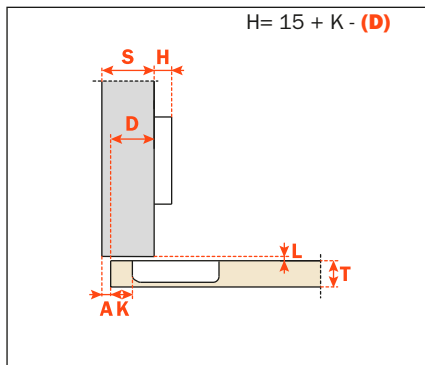

C8_6CE9

Arm 5

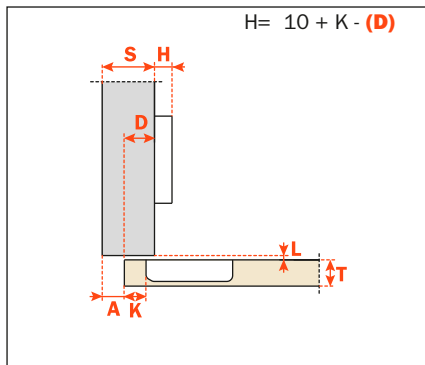

C8_6JE9

Arm 9

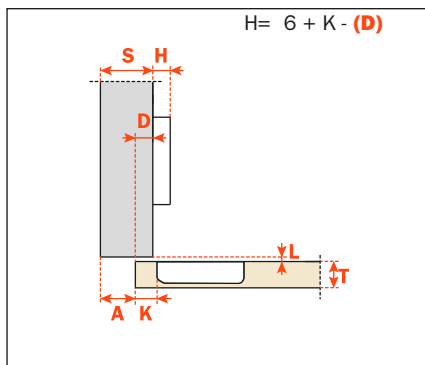

C8_6LE9

Arm 17

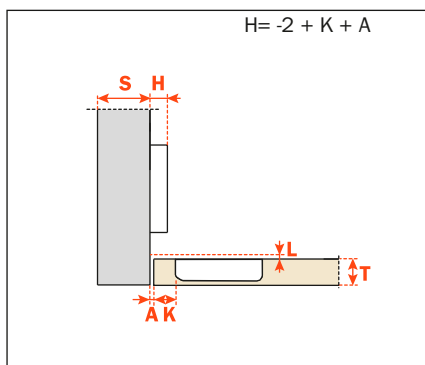

C8_6SE9